



# **USER'S MANUAL**

## **SYA SERIES HIGH PRECISION PRESS**

The People's Republic of China

SHENZHEN LIHAO MACHINE EQUIPMENT CO., LTD

# SYA SERIES PRESS

Dear Customer:

Hello! Welcome to use our company's press!

Our company specializes in the production of all kinds of stamping machines. This machine is manufactured and manufactured in strict accordance with ISO9001:2008 international quality certification procedures and standards before leaving the factory, and has been strictly inspected.

Based on years of customer feedback and our service experience, proper use and timely maintenance are important factors for the machine to perform its best performance and maintain its original accuracy and vitality for a long time. Therefore, we hope this manual will help you make full use of the functions of this machine.

If you have any questions while reading this manual or using the press, please contact us.

Thank you for buying our company's punch press. In order to use the punch press correctly, please read this manual carefully before use.

Please be sure to hand this manual to the actual user of the press. If there is any change, we will not give further notice.

The operation control circuit is divided into PC type and UL type. Each type is suitable for each model.

PC type: according to the construction specifications and safety devices of the power punch press, it meets the requirements of the punch press type.

V type: suitable for general punch press (variable speed type).

S type: suitable for general punch press (fixed speed type).

H type: suitable for high speed punch press.

UL type: conforms to American standard specifications.

The types, methods and other safety measures of each model are as follows:

project	type	PC		UL	remarks
		V	H		
Operation of the press	adjusting microinch	O	O	O	O: Standard electrical circuit  OP: Special electrical circuit device
	A safe journey	O	O	O	
	A journey	O	O		
	Linked	O	O	O	
method of operation	both hands	O	O	O	
	Mobile control panel	OP	OP	OP	
	foot pedal	OP	OP		
	single hand	OP	OP		
Safety device	Two-handed operation	O	O	O	
	photoelectric type	OP	OP	OP	
	Wrongfully detected	OP	OP	OP	
	Overload detected	OP	OP	O	
safe measure	Detection of failure of compound solenoid valve	OP	OP	OP	
	Leverage up	OP	OP	O	
	The exception return button	O	O	O	
	Safe electrical box			O	
	Low speed protection	O		O	
	Emergency stop return button	O	O	O	
	Lower dead point protection				
	Second test failure detected	O	O	O	
The system is detected twice in a chain	O	O	O		

## Safety precautions

Before installation, operation, maintenance and inspection, please be sure to read this manual carefully for correct use. After fully understanding the principle of this machine, safety conditions and all precautions, then use the operation.

Explanation:



Warn!

Indicates that an electric shock may be caused by a misoperation.



Pay attention to!

Do not put your hands or other objects into the danger area to avoid accidents.



Warn!

The machine must be grounded before operation, and the grounding method should comply with national standards or corresponding international standards. Otherwise, it may cause electric shock.



Warn!

Do not put your hands or any part of your body into the danger area.

# Catalogue

<b>1. Handling and installation .....</b>	<b>- 1 -</b>
1.1 Handling .....	- 1 -
1.2 Installation .....	- 4 -
<b>2. Pre-operation preparation .....</b>	<b>- 7 -</b>
2.1 Use of lubricating oil .....	- 7 -
2.2 Connection of air source .....	- 8 -
2.3 Power connection .....	- 8 -
2.4 Special precautions before installing power supply .....	- 9 -
<b>3. Schematic diagram of operation of punch press .....</b>	<b>- 11 -</b>
3.1 Operation panel diagram .....	- 11 -
3.2 Decoder diagram .....	- 12 -
3.3 Schematic diagram of pressure device adjustment .....	- 12 -
<b>4. Operation procedure .....</b>	<b>- 13 -</b>
4.1 Introduction of main functions .....	- 13 -
4.2 Human-machine interface setting and operation method .....	- 13 -
4.3 Introduction of the main functions and setting methods of the cam controller .....	- 14 -
4.4 Electronic cam protection and alarm processing .....	- 21 -
4.5 Operation panel indicator light description .....	- 22 -
4.6 Selection of operation mode .....	- 23 -
4.7 Emergency stop button .....	- 24 -
4.8 Pre-start inspection and preparation .....	- 24 -
4.9 Operation method .....	- 25 -
4.10 Operation selection .....	- 26 -
4.11 Machine shutdown sequence .....	- 26 -
4.12 Precautions .....	- 26 -
<b>5. Select accessories to adjust the operation .....</b>	<b>- 28 -</b>
5.1 Manual procedures .....	- 28 -
5.2 Electromotive force slider adjustment (A80-A260) .....	- 28 -
5.3 Balance cylinder pressure adjustment .....	- 29 -
5.4 Maintenance inspection record .....	- 29 -
<b>6. Security section .....</b>	<b>- 33 -</b>
6.1 To ensure the safety of operators and maintain the operation of the machine, please follow the following precautions ...	- 33 -
6.2 Safe Distance (D) .....	- 35 -
<b>7. Maintenance .....</b>	<b>- 36 -</b>

7.1 Pressure, electrical and lubrication maintenance .....	- 36 -
7.2 Operation and maintenance precautions: .....	- 37 -
7.3 Maintenance of electrical parts .....	- 40 -
<b>8. Cause and troubleshooting of faults .....</b>	<b>- 42 -</b>
8.1 The upper and lower molds are clamped and released .....	- 42 -
8.2 Methods for disengagement of overload safety devices (limited to hydraulic overload safety devices): .....	- 42 -
8.3 Overload reset by hydraulic pressure .....	- 42 -
<b>9. Lubrication .....</b>	<b>- 44 -</b>
9.1 Lubrication system diagram (electric lubrication system) .....	- 44 -
9.2 Lubrication system diagram (manual lubrication system) .....	- 45 -
9.3 Lubrication instructions .....	- 46 -
9.4 Oil change cycle .....	- 46 -
9.5 Precautions: .....	- 46 -
<b>10. Description of forming function of punch press .....</b>	<b>- 48 -</b>
10.1 Standard configuration .....	- 48 -
10.2 Selection of accessories .....	- 49 -
10.3 Slider construction .....	- 49 -
10.4 Special devices .....	- 51 -
<b>11. Machine use range and life .....</b>	<b>- 54 -</b>
<b>12. Punching press assembly diagram .....</b>	<b>- 54 -</b>
<b>13. Stamping machine specifications and parameters .....</b>	<b>- 55 -</b>
<b>14. Forging press accuracy requirements .....</b>	<b>- 58 -</b>
<b>15. Three factors that determine the capacity of a punch press .....</b>	<b>- 59 -</b>
15.1 Pressure capacity .....	- 59 -
15.2 Torque capacity .....	- 60 -
15.3 Do function .....	- 60 -
15.4 Card model .....	- 60 -
15.5 Allowable eccentricity capability .....	- 60 -
15.6 Number of intermittent trips .....	- 60 -
<b>16. Appendix .....</b>	<b>- 61 -</b>
16.1 Electrical diagram .....	- 61 -
16.2 Touch screen .....	- 67 -

## 1. Handling and installation

### 1.1 Handling

#### 1.1.1 Acceptance

Each of our company's stamping machines has been prepared for transportation before delivery, so that it will still be intact when it arrives at the destination. When you receive the stamping machine, please first check whether there is any damage to the machine surface. If there is any damage, please inform our company and the person in charge of transportation to ask them to check.

If there is no damage, please check whether the accessories are complete. If there are any missing parts, please inform the company and the delivery person to check them.

#### 1.1.2 Handling

Because the volume and weight of the punch itself are large, ordinary mechanical lifting methods cannot be used. Therefore, when lifting, we must consider the range of force that the crane and steel cable can bear, and pay attention to the safety of protruding parts of the machine at any time.

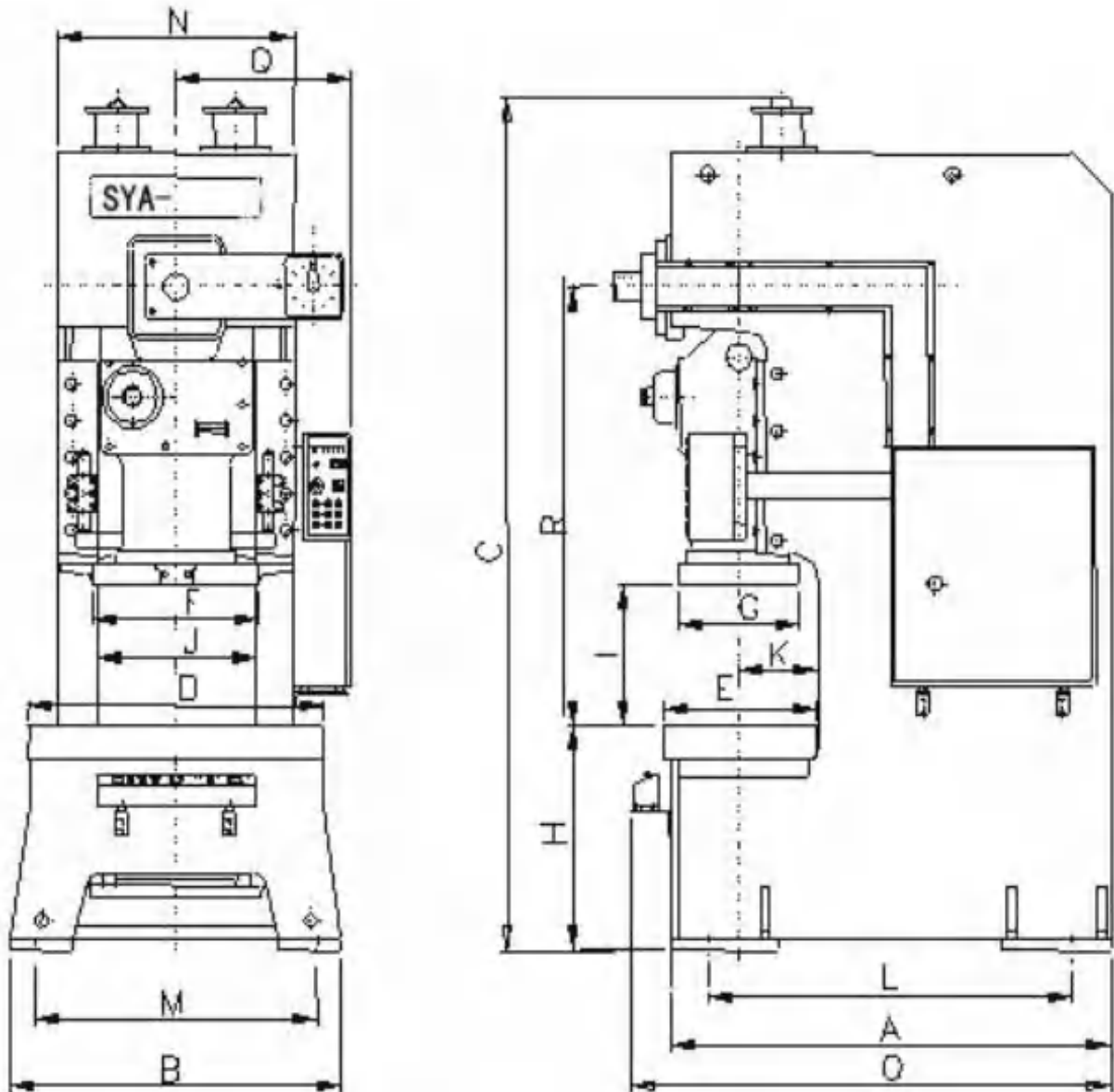

**External dimensions of A series punch press**

External dimensions	15	25	35	45	60	80	110	160	200	260	300	400
A	1100	1100	1200	1400	1420	1595	1720	2140	2440	2605	2615	2995
B	740	840	900	950	1000	1170	1290	1390	1690	1850	1860	2020
C	2135	2135	2345	2425	2780	2980	3195	3670	4075	4470	4504	5025
D	680	680	800	850	900	1000	1150	1250	1400	1500	1600	1650
E	300	300	400	440	500	550	600	800	820	840	860	900
F	300	300	360	400	500	560	650	700	850	950	1250	1350
G	220	220	250	300	360	420	470	550	630	700	750	800
H	725	800	790	800	795	840	840	910	1030	1030	1030	1190
I	260	260	290	320	420	480	530	650	650	750	750	800
J	426	444	488	502	526	534	616	660	790	900	890	1050
K	150	160	205	225	255	280	305	405	415	430	440	450
L	980	980	1040	1170	1180	1310	1420	1760	2040	2005	2005	2385
M	600	700	800	840	890	980	1100	1200	1400	1560	1560	1730
N	540	540	620	670	720	780	920	1000	1160	1300	1310	1470
O	1275	1275	1375	1575	1595	1770	1895	2315	2615	2780	2905	3285
P	278	278	278	313	333	448	488	545	593	688	698	700
Q	447	447	560	585	610	620	685	725	805	875	1009	1089
R	935	935	1073	1130	1378	1506	1650	1960	2188	2460	2495	2660

### 1.1.3 Lifting precautions

- (1) Whether the surface of the steel cable is damaged.
- (2) The steel cable is prohibited from being lifted in a 90 manner.
- (3) The surface of the steel cable shall be wrapped with waste cotton cloth at the bent corner.
- (4) Do not use chains for lifting.
- (5) When the machine must be moved by hand, it can only be pulled, not pushed forward.
- (6) Keep a safe distance during lifting.

### 1.1.4 Lifting steps

- (1) Pass the round rod (depending on its aperture size) through both sides of the frame.
- (2) Use 20mm steel cable in a cross shape to pass through the bottom hole of the fixed frame and the smooth round bar.
- (3) Place the crane hook in the proper position, slowly leave the ground and make appropriate load adjustment to keep the machine flat.
- (4) After confirmation of safety, lift and move carefully.

### 1.1.5 Unloading instructions

The front of the machine is uneven, and there are electrical boxes and air pipes on both sides, so it cannot be overturned or turned horizontally. The only way is to land on the back of the figure, but it is best to pad with wooden blocks to avoid damaging the outside of the machine.

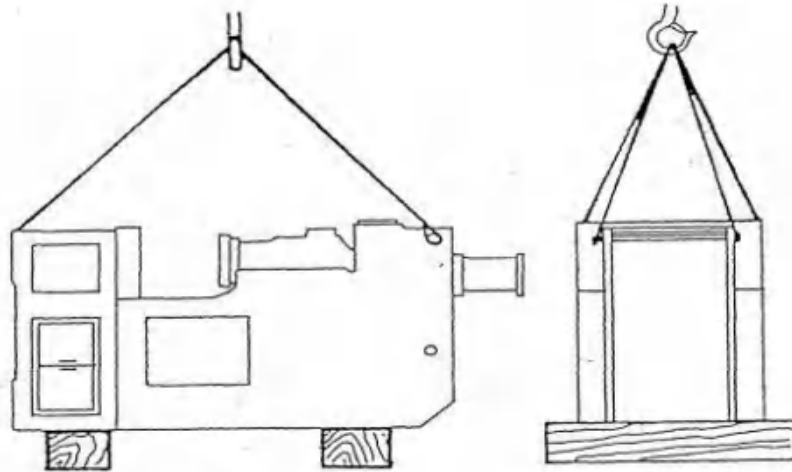

The length of the selected pad must be greater than the width of both sides of the press.

If the height of the plant gate is lower than the height of the press, or it is not convenient to lift the crane, the press can be inverted and then moved a short distance with the help of the round bar, but be careful to prevent accidents. The selected wood must be able to bear the load of the press.

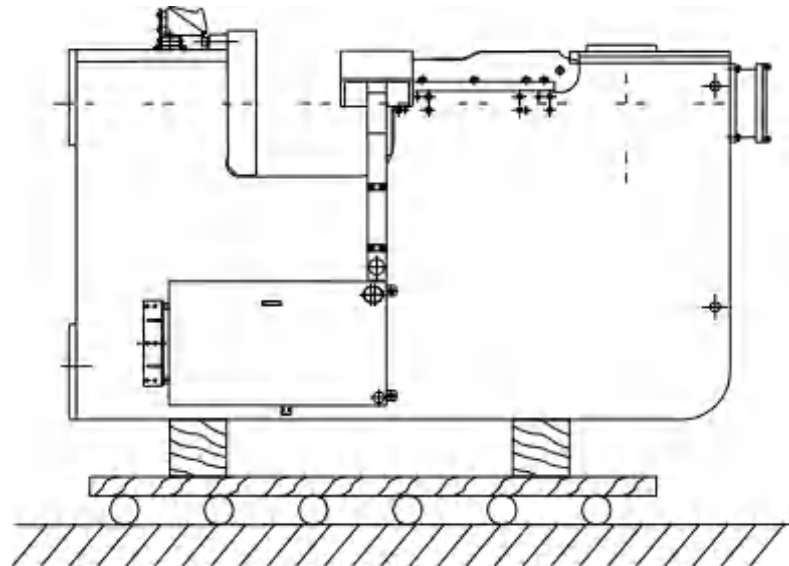
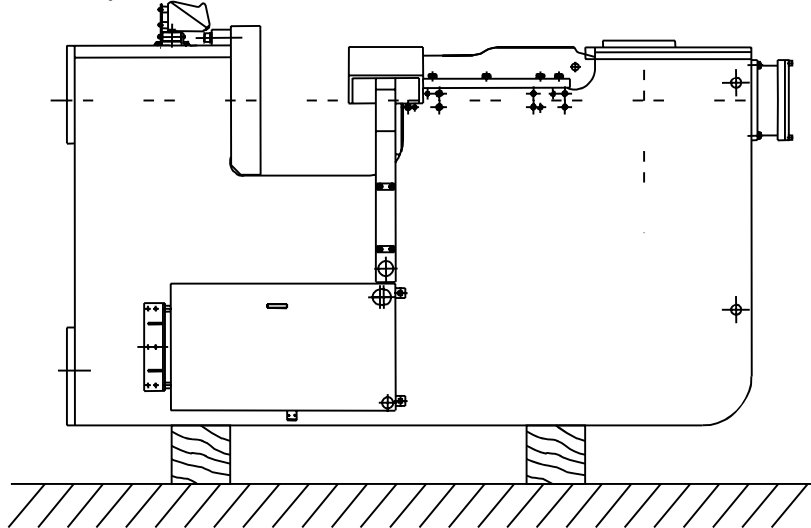

## 1.2 Installation

### 1.2.1 Installation of the rack

- (1) Install the shock absorber foot at the bottom of the rack.
- (2) The machine is coated with rust-proof oil during transportation. Please wipe it clean before installation.
- (3) Use a precision level to measure the level during installation.
- (4) When measuring the level of the rack, please check whether the rack is locked first.
- (5) If the rack surface is self-installed, pay attention to keeping the contact surface between the rack and the rack plate clean, and do not leave foreign objects such as paper, metal fragments, screws, washers, dirt and other residues between the workbench and the rack.

Precautions for A series installation:

⇒ 1. Before the press falls, please install the shock absorber feet first! As shown in the figure

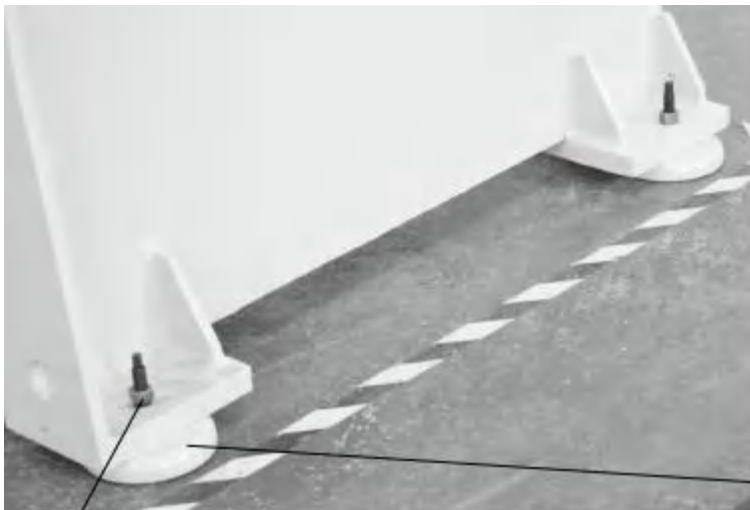

Anti-vibration feet

Please adjust the levelness of the press by rotating the screws

Note: The shockproof foot should be at least as large as the foot of the punch press so that the contact surface of the foot can bear the weight of the punch press evenly.

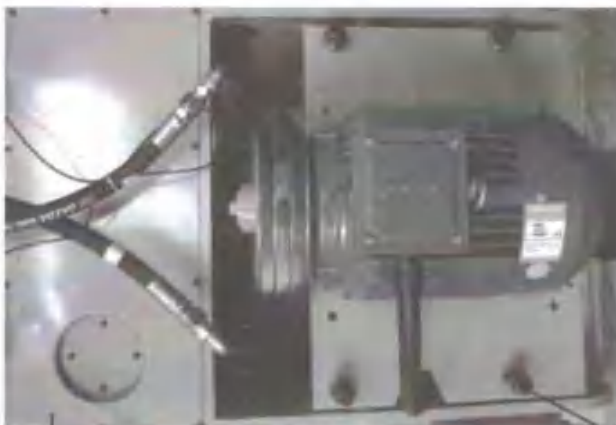

Top View after motor positioning  
马达定位后俯视图



Tightness of bolsts adjust by four bolsts on motor base  
皮带的松紧由马达座的4个螺杆来调整

⇒2. If the motor is not installed, please put the motor into the corresponding position after the press falls, as shown in the figure.

⇒3. Before the installation and debugging of the punch press, please prepare electricity, gas and oil, as follows:

Electricity: 380V,50Hz

Air: pressure above 6 kg, preferably dried

Gear oil:(add from the tank cover, after adding, please add glass glue around to prevent the oil in the tank from splashing out. Do not add too much oil, please do not exceed 2/3 of the height of the oil mark.)

type	A25	A35	A45	A60	A80	A110	A160	A200	A260	A315	A400
capacity	16L	21L	22L	32L	43L	60L	102L	126L	135L	145	160

Butter: 18L (O# butter)

Overloaded oil: 3.6L (oil at 1/2 tank gauge)

Balance oil: 32# (one cup of balance oil)

⇒4. Adjust the level of the punch press

⇒5. Electrical wiring: as shown in the figure



### 1.2.2 Installation of the main motor

The active motor should be combined with the punch press as far as possible. If the motor must be removed due to transportation restrictions, the reinstallation method is described below:

- (1) Open the parts package and check for damage.
- (2) Clean the motor, motor gear wheel, flywheel groove and clamping block. Do not let the solution drop into the motor. Clean the V belt with cloth. Do not use the solution to clean the belt.
- (3) Install the motor to the engagement position, but do not fully lock it. Support the weight of the motor with a sling before the screw is locked.
- (4) Measure the alignment line of the motor sprocket and the flywheel with a measuring tool, and move the motor until the alignment line is correct. If the alignment line of the sprocket and the pulley is not aligned, the belt groove and the motor bearing will be worn. Tighten the motor seat screw when the alignment line is aligned.
- (5) Move the motor slightly towards the flywheel so that the V belt can slide in the pulley without strain.

Note: Do not use strong force to install the belt on the groove of the pulley. After installation, the belt tension should be about 1/2" under the thumb.

### 1.2.3 Level adjustment

- (1) Clean the rack thoroughly to increase the accuracy of the horizontal reading.
- (2) A precision level is placed at the front edge of the rack for three measurements at the front, middle and rear.
- (3) If the front and rear edges are lower, the shockproof feet can be used to adjust the bottom of the frame to make the left and right completely horizontal.

#### Pay attention to:

- (1) The shockproof foot should be at least as large as the foot of the punch press, so that the contact surface of the foot can bear the weight evenly.

- (2) In order to be safe, the level should be checked again after one month of use. (If there is an error, the base screw can be slightly adjusted to the level). Otherwise, check it every six months. Confirm the mechanical level, so that the maintenance effect of the performance of this machine is significant. 2. In order to be on the safe side, the level should be checked again after one month of use. (If there is an error, the base screw can be slightly adjusted to the level). Otherwise, check it every six months. Confirm the mechanical level, so that the maintenance effect of the performance of this machine is significant.

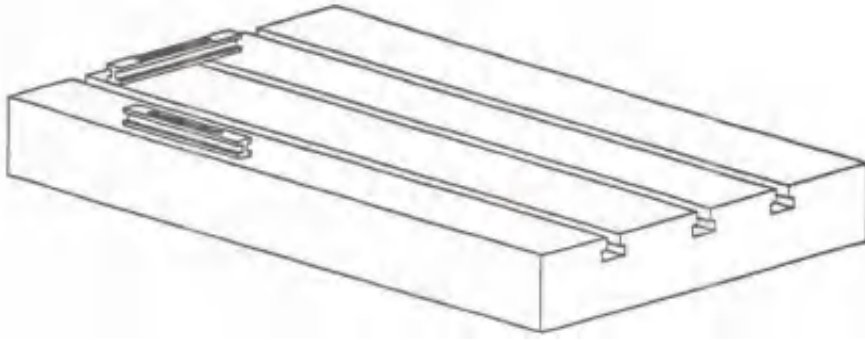

## 2. Pre-operation preparation

### 2.1 Use of lubricating oil

润滑油使用表  
Lubrication List

目录 NO.	位置 Position	注油方式 Method of lubrication	注油频率 Frequency	油室容量 Capacity of Lubricant Cell										厂牌					
				15	25	35	45	50	80	110	160	200	260						
1.	平衡器 Counter Balance	手动机油泵 Manual Oil Pump	每天一次, 每次五下 In/line Times/In/line/Day	400cc	400cc	400cc	400cc	400cc	400cc	400cc	400cc	400cc	400cc	400cc	400cc	400cc	MOBIL(美孚) Mobil gear 626	Shell(壳牌) Shell Omala 68	Esso (埃索) Spartian EP 68
2.	曲轴及传动轴瓦 Crank Link And Bushing	手动黄油泵 Manual Grease Pump 电动黄油泵(选用配件) Motorized Grease Pump(Optional)	每小时 Every Hour 每八小时 Every 8 Hours	600cc	600cc	600cc	600cc	600cc	600cc	600cc	600cc	600cc	600cc	600cc	600cc	600cc	Mobilux EP0	Shell/Alvania FFR0	Beacon EP0
3.	齿轮箱 Main Gear Box	油箱 Oil Tank	1500小时要换 Replaced Every 1500 Hours	-	16L	21L	22L	32L	32L	43L	60L	102L	126L	140L	140L	140L	Mobil gear 626	Shell Omala 150	Spartian EP 150
4.	滑块导轨 Slide Guide Rail	手动黄油泵 Manual Grease Pump 电动黄油泵(选用配件) Motorized Grease Pump(Optional)	每小时 Every Hour 每八小时 Every 8 Hours	600cc	600cc	600cc	600cc	600cc	600cc	600cc	600cc	600cc	600cc	600cc	600cc	600cc	Mobilux EP0	Shell/Alvania EPR0	Beacon EP0
5.	过负载油箱 O.L.P. Oil Tank	油箱 Oil Tank	每日检查, 一年更换 Check daily Change yearly	3.6L	3.6L	3.6L	3.6L	3.6L	3.6L	3.6L	3.6L	3.6L	3.6L	3.6L	3.6L	3.6L	Mobil DTE24	Shell/Tellus Oil 32	Nuto H 32
6.	模垫 Die Cushion	手动黄油枪 Manual Grease Gun	每小时 Every Hour	-	-	-	-	-	-	-	-	-	-	-	-	-	Mobilux EP0	Shell/Alvania EPR0	Beacon EP0
7.	空气配管 Pneumatic System	润滑器 Lubricator	每日检查 Check daily	170cc	170cc	170cc	170cc	170cc	170cc	170cc	170cc	170cc	170cc	170cc	170cc	170cc	Mobilux EP0	Corena Oil R.32	Atla 32 H 32



注意: 齿轮箱内之润滑油在新车运转后三个月内 (750 小时) 更换, 其后每六个月内 (1500 小时) 更换并清洗油槽, 每半年检查滑油块视情况再加 50-100cc.

Note: Change the Gear Box Oil in three months (approximate 750hrs) after beginning operation and once every six months (approximate 1500hrs) thereafter and clean inside of Gear Box. Check the ball base every half year, adding 50-100cc according to the remaining oil quantity.

## 2.2 Connection of air source

The air compressor piping must be connected to the pipeline behind the press, with a diameter of 1/2B. The factory piping is listed in the table below, and the required air pressure is 5Kg/cm<sup>2</sup>. However, the distance from the air source to the assembly location must be within 5 meters. First, test the air output to check for any dust or water accumulation inside the pipes. Next, open the main valve and install the air inlet at the air connection port.

A-Model series	15	25	35	45	60	80	110	160	200	260	315	400
Factory pipe diameter	1/2G											
Air consumption per minute	24.8	24.8	19.5	25.3	28.3	28.9	24.1	29.4	40.7	48.1	49	49.6
Number of intermittent trips SPM	60	60	48	35	35	30	25	20	18	18	16	15
Air tank capacity	clutch	—	—	—	—	—	35	63	92	180	180	180
	balancer	15	15	17	18	19	21	38	63	92	180	180
The required air compressor HP	3	3	3	3	3	3	5	5	5	5	5	5

Note: air consumption per minute refers to the air consumption required by the clutch during intermittent operation.

## 2.3 Power connection

First, switch the air switch to the "OFF" position. Then, turn the power switch on the control panel to the "OFF" position to isolate the control panel from the power supply. After confirming that the fuse is intact, connect the power supply to the terminals inside the control panel according to the specifications of this press and the main motor's power, following the table and electrical equipment standards.

Project model	Main motor power KW	Wire cross-sectional area (mm <sup>2</sup> )		rated current (A)		starting current (A)		Mechanical negative Capacity (KVA)
		220V	380/440V	220V	380/440V	220V	380/440V	
A-15	2.2	2.5	2.5	9.3	5.8	68	39	4
A-25	4	4	2.5	9.3	5.8	68	39	4
A-35	4	4	2.5	9.3	5.8	68	39	4
A-45	5.5	6	2.5	15	9.32	110	63	4
A-60	5.5	6	2.5	15	9.32	110	63	6
A-80	7.5	10	4	22.3	13	160	93	9
A-110	11	16	6	26	16.6	200	116	12
A-160	15	25	10	38	23	290	168	17
A-200	18.5	35	16	50	35	360	209	25
A-260	22	35	25	63	43	480	268	30
A-300	30	70	35	79	59	545	360	40
A-400	37	95	35	97	73	670	450	45

Note: The above wire specifications are national standard copper wire or cable.

## 2.4 Special precautions before installing power supply

### Correct power wiring:

- (1) The power supply must be reliably grounded and the grounding wire must be completely separated from the working neutral.

According to the relevant standards and specifications for general factories, the power supply system of the press should be TC-S or TC-N-S. This means that the factory's power supply system is a three-phase four-wire system. When the power is introduced to the press equipment through a tap changer box, it should be a three-phase five-wire system, with the working neutral line and protective earth wire completely separated. This setup effectively prevents static electricity and noise from interfering with the control system and other equipment, thus avoiding malfunctions and ensuring the safety of the operators.

- (2) Wiring method:

A) Use an electric pen or three-electric meter to measure the line (N line) without voltage and connect it to the power terminal S of the control box of the punch press. The other two lines can be connected to the three lines A, B and C at will.

B) If the motor runs in the opposite direction, the lines of any two phases should be switched, and the N line must not be switched.

- (3) Wrong wiring mode will lead to the wrong operation of solenoid valve (SV), causing danger to personnel and equipment. Please pay special attention to check.

This machine has been subjected to strict quality control, thorough inspection and contingency measures when shipped, but in order to consider the abnormal situation in case of, all inspection items are listed for the operator's reference and memorization.

The specific inspection items can be referred to the following table:

	inspection item	standard	abstract
<b>initial inspection</b>	(1) Is the rack cleaning in good condition? (2) Is the oil level in the tank appropriate? (3) Do you find any abnormal conditions when turning the flywheel with the rotary rod? (4) Is the cross-sectional area of the power cable in accordance with the regulations?	Nothing should be placed on the rack and the oil level should not be lower than the standard.	
<b>Check after refueling</b>	(5) Is there any oil leakage in the pipe joint? (6) Did the pipe get cut or fractured?		
<b>Check after opening the valve</b>	(7) Does the clutch air pressure gauge indicate the rated value? (8) Is there any leakage in each part? (9) Is the action of the electromagnetic valve of the clutch and brake normal? (10) Is there any leakage in the clutch cylinder and rotating joint? (11) Whether the clutch works smoothly.	5kg/cm <sup>2</sup>	
<b>After the power is on</b>	(12) The power switch is turned on and the indicator light is on. (13) Put the running selection switch in the "inch motion" position. When pressing and releasing the two operation buttons, check whether the clutch actuation is light? (14) After pressing the operation button, press the emergency stop button to check whether the clutch can be separated. Whether the emergency stop button can be set to the "inch motion" position and keep pressing the punch press operation button (15) Check for abnormal noise or unusual heaviness?	The green light is on	

<b>The main motor starts</b>	(16) Main motor indicator light on? (17) Check that the steering of the flywheel is correct? (18) Check whether the flywheel starts and accelerates normally? (19) Is there any abnormal sound of the V-belt sliding?	The green light is on	
<b>running operation</b>	(20) Check whether the inch motion performance is good when the inch motion is running? (21) When the "An Yi" operation or "one trip" operation is performed, is the action normal? (22) Will it start again if I continue to press the operation button? (23) Is the stop position correct? (24) Will the stop position be biased? (25) When the inspection is carried out in "linked" operation, does it stop at the specified position after pressing the linked stop button? (26) Check whether the emergency stop button is stopped immediately after pressing it.	Do not restart The upper dead center position is $\pm 15^\circ$ $\pm 5$ or less $\pm 15$ or less $\pm 5$ or less Stop confirming immediately	
<b>Slider adjustment</b>	(27) When the slider adjustment switch is turned on, the abnormal operation indicator light is on? (28) Is the electric slider adjusted to stop automatically at the upper and lower limits? (29) Adjust the specifications of the mold height indicator		electrodyn amic type

### 3. Schematic diagram of operation of punch press

#### 3.1 Operation panel diagram

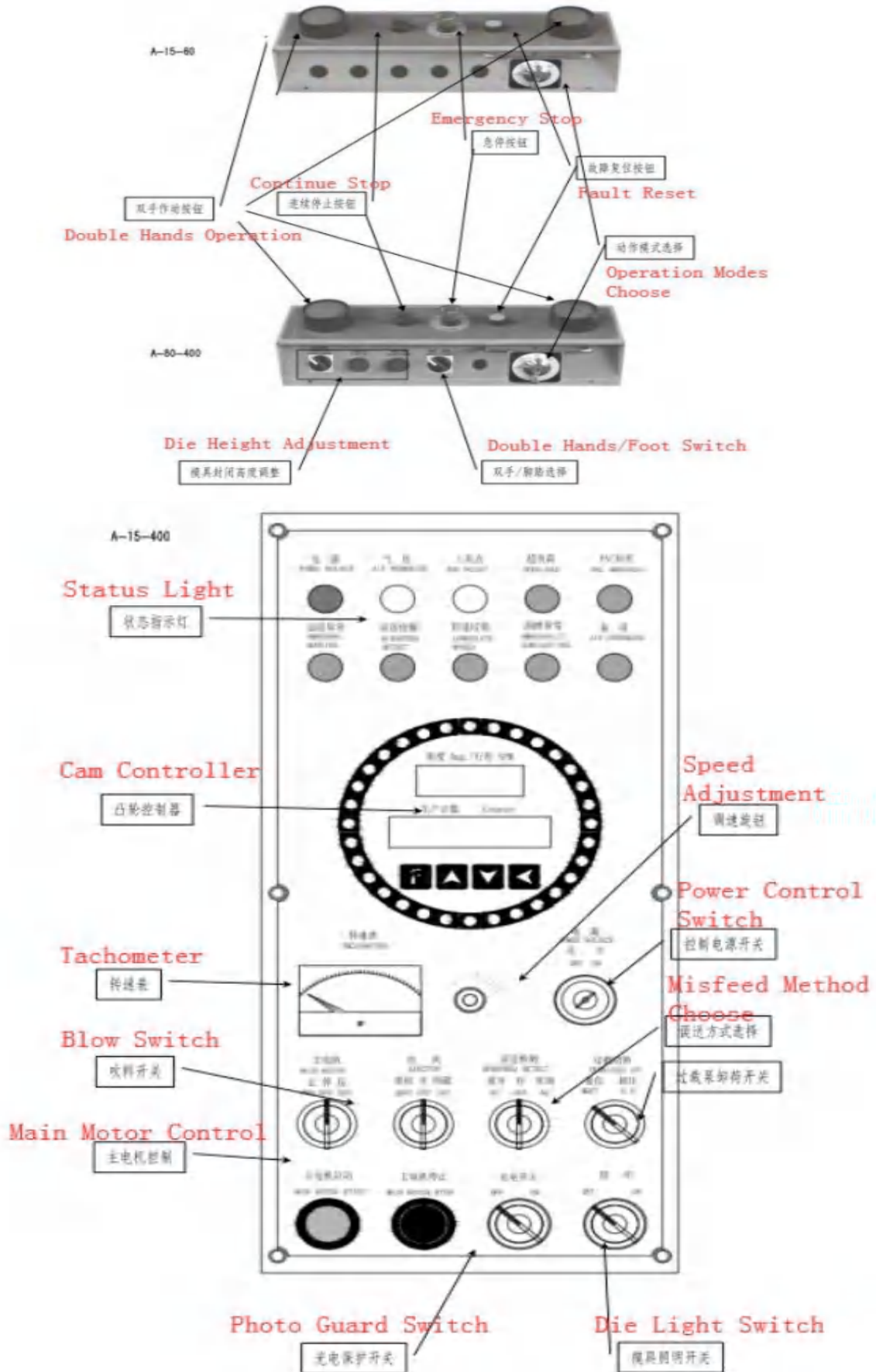

### 3.2 Decoder diagram

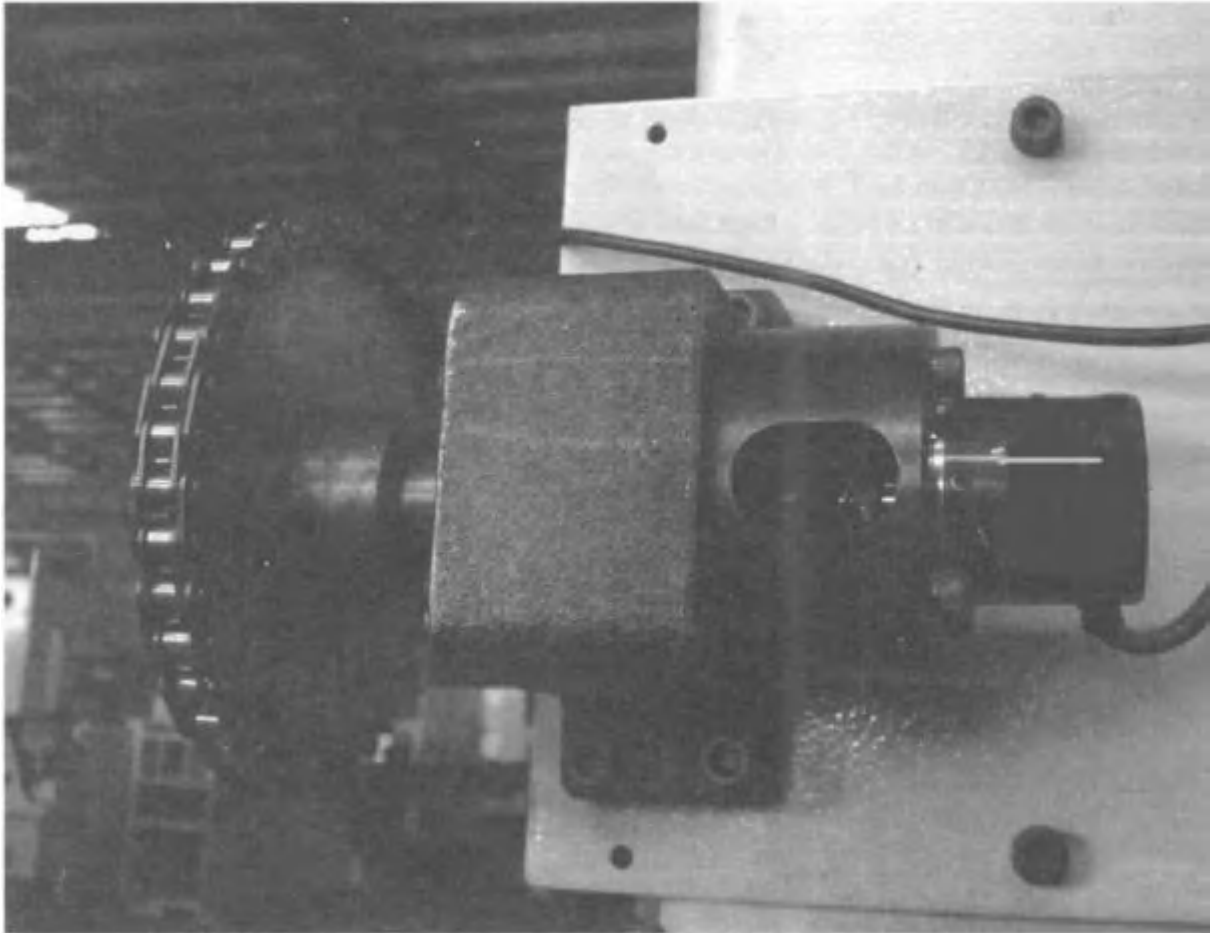

### 3.3 Schematic diagram of pressure device adjustment

- (1) Overload device
- (2) Peacekeeper
- (3) Clutch, brake
- (4) Blow-off device

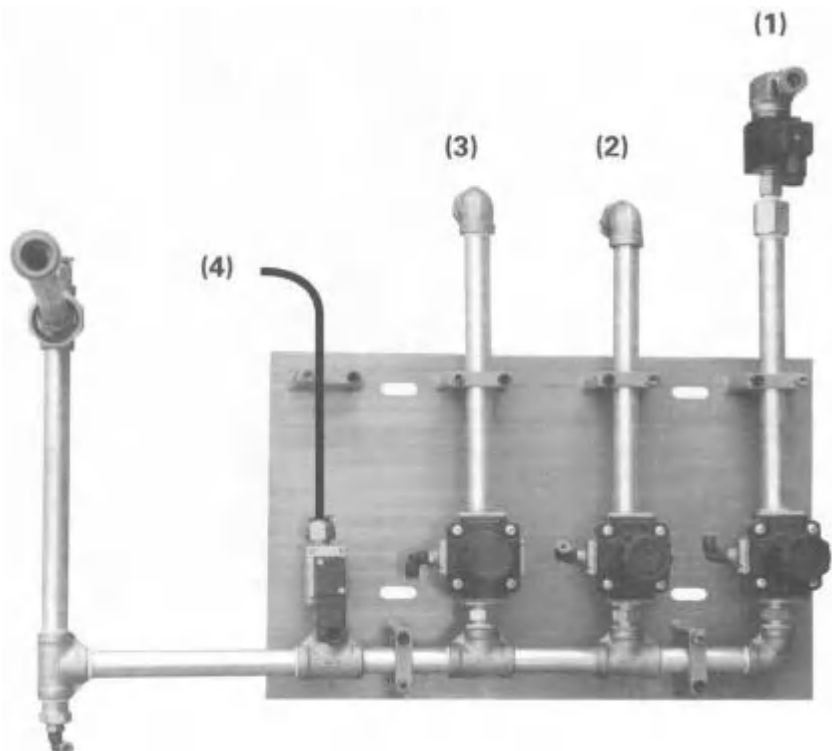

## 4. Operation procedure

### 4.1 Introduction of main functions

This "High-speed Precision Punching Machine Control System" features high-speed digital and analog signal acquisition, a large number of input and output points, and more comprehensive analog cam control. Compared to traditional PLC controllers, it offers higher automation, greater precision, more advanced detection methods, safer operation, and the addition of many new functions (our patented technology), placing it at the forefront of the industry.

Please note: the user must be well grounded when installing the machine. Because of static electricity and interference in the operation of switching power supply and frequency converter, the analog data accuracy of this control system will be affected.

The main functions of this system compared with the traditional controller are:

- (1) The control system is safer; the control circuit adopts double loop control, and when danger occurs, the action signal of the double valve can be strongly disconnected through the emergency stop.
- (2) Simulate the function of cam. The system uses a 720P/differential output rotary encoder, the control accuracy of simulated cam is twice that of traditional PLC, and the anti-interference ability is stronger.
- (3) Mold machine protection function. This special control system is equipped with a pressure sensor or strain sensor, can measure and calculate the stamping tonnage, can immediately stop to effectively protect the mold and machine;
- (4) Material feeding monitoring function. By adding the corresponding detection components, the material feeding accuracy of the material feeding device can be effectively monitored;
- (5) Visualization of Angle Settings;
- (6) Multi-machine networking function. This system can realize remote view, control and management functions of computer network.

### 4.2 Human-machine interface setting and operation method

#### 4.2.1 Motor operation button



Before starting the main motor, switch the operation mode on the control box to the 'Off' position. Then, rotate the first switch on the main panel to either 'Forward FWD' or 'Reverse REV', and press the green 'Main Motor Start' button. The LED inside the green cover will light up, indicating that the motor operation signal has been sent to the corresponding speed control device (such as a frequency converter or electromagnetic speed controller).

**For Your Attention:**

- (1) According to relevant national regulations and considering the safety of operators, the operation specifications of this system are as follows: the motor can only be switched on and off in "cut" mode.
- (2) When the motor is switched from forward to reverse, it is necessary to wait for the motor to stop completely before starting in reverse.

**4.2.2 Operation mode**

According to the relevant safety standards of EU EN691, EN692 and Japanese Ministry of Labor, the standard configuration of all press machines in LiHao is equipped with a lock mode switching switch as shown in the figure on the right.

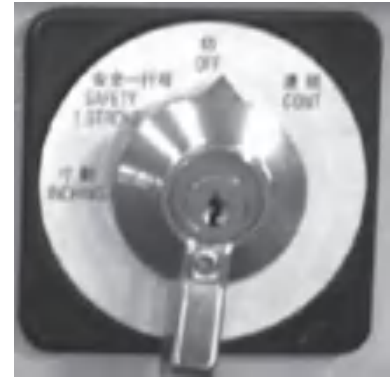
**Motion — travel mode**

Insert the key into the lock, turn it clockwise to keep it in a right-hand position. Turn the outer handle counterclockwise to align the arrow with the 'INCH' position. Press the actuation button with both hands; the presser slide will start moving. If both hands remain on the button, the slide will continue to move. If either hand releases the button, the slide will stop immediately.

**Safety one trip — Trip mode**

By operating the 'inch motion' mode, the crankshaft angle is adjusted to the 'top dead center angle.' Once the 'top dead center' indicator on the front panel lights up, switch the mode to 'safety one stroke' mode. Hold both start buttons simultaneously (with a time interval of no more than 0.3 seconds), and the machine will start running. During operation, if the crankshaft passes the bottom dead center (greater than 180°), release the start buttons. The machine will automatically stop at the top dead center. If an alarm occurs, adjust the machine's status, press the 'reset' button to clear the alarm, and then proceed with the operation.

**The sequential pattern**

By operating the 'inch motion' mode, rotate the crankshaft angle to the 'top dead center angle.' Once the 'top dead center' indicator light on the front panel lights up, switch the mode to 'continuous' and press both start buttons simultaneously. The machine will start running. Note that you need to hold down both buttons for more than 5 seconds (the linked indicator light will flash). If you release the buttons during this time, the machine will stop. Continuous rotation mode will not work. If an alarm occurs, adjust the machine's status, press the reset button to clear the alarm, and then the machine can operate again.

**4.3 Introduction of the main functions and setting methods of the cam controller****4.3.1 Introduction of main functions**

- The cam controller integrates many functions such as angle, stamping speed display, automation assistance, quantity preset, angle tracking, sensor fault and so on. It has the advantages of safety, reliability, strong durability, strong anti-interference ability, simple setting and powerful function. The technology is advanced.

- ☆ The cam Angle setting is dynamically indicated to make the setting more user-friendly.

- ☆ Super reliability, multiple protection

- multifunctional

Two brake outputs, two incremental outputs, four programmable trimmer cam outputs, four trimmer cam outputs, one production count arrival output, one system normal indication output. A total of 14 outputs.

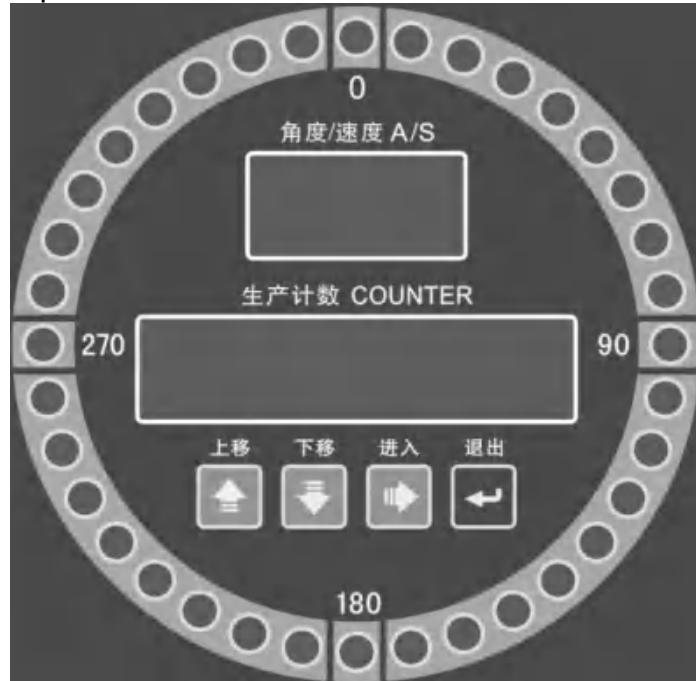

The upper three-digit LED display is used to display the stroke number/angle value, and the lower six-digit LED display is used to display the working count.

The digital display is used to display a variety of information required by the user. At the same time, in the setting state, the flashing position indicates the current parameter focus, which indicates the location of the user cursor.

#### 4.3.2 Menu

- ◇ Stroke count/angle value display
- ◇ Production count display: 6 digits, maximum count 999999.
- ◇ Vertex positioning: can automatically compensate for the deviation of vertex positioning.
- ◇ Cam setting: 4 cam outputs for programmable cutting, 4 cam outputs for cutting, 2 A and B incremental outputs (360 lines)
- ◇ Route 1 production count arrives at the output.
- ◇ Set the lower stop point (180 degrees).
- ◇ Angle sensor forward/reverse setting.
- ◇ System parameter password protection.
- ◇ Line break detection function
- ◇ Shaft break detection function
- ◇ Input and output status is displayed in real time
- ◇ System abnormal alarm.
- ◇ Production count is suspended and cleared to zero

#### Go to Settings

When the device is idle, hold **[F1]** and **[F2]** key for more than 3 seconds to enter the setting state. At this time, the four-digit display above will flash. Then use **w** or **w** key to select the menu, and press **Enter** to enter the sub-menu. After selecting the menu with the key, press **Enter** to enter the sub-menu.

### 4.3.2.1 Stroke number/angle value display

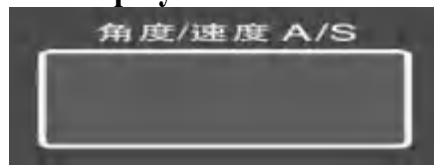

The control system uses a high-precision absolute encoder to realize the collection of angle signals. When the stroke is more than 8 times per minute in continuous or inch motion mode, the stroke speed is displayed; otherwise, the Angle value is displayed; in other working modes, the Angle value is displayed.

### 4.3.2.2 Production count display

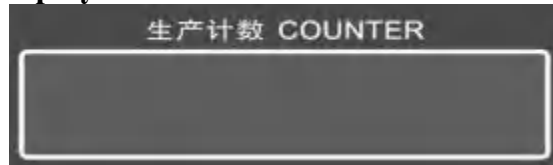









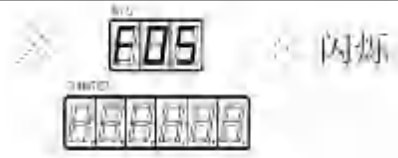

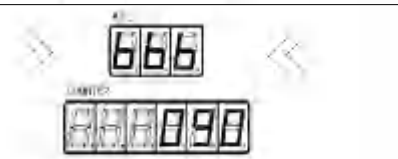

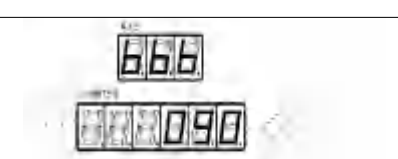

The slider counts 1 at the bottom dead point of production and accumulates the quantity. If the zeroing action is not performed, the value will be reset to 0 when it reaches 999999. If manual reset is required, it can be achieved by the following two ways:

- ◇ Hold down  for more than 3 seconds.
- ◇ Hold down the white button on the control box for 5 seconds.

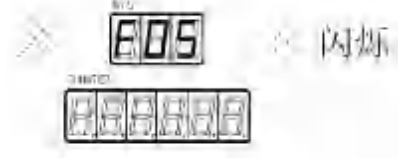
### 4.3.3 Setting of cam parameters

#### 4.3.3.1 Setting steps of cam parameters

1		Enter the setting state and press  or  select the cam number to be set.
2		Press  the key to enter the submenu. At this time, the name of the submenu item is displayed and flashes. Press  or  select the item to be adjusted
3		Press  the key to adjust. At this time, the content of the submenu item flashes. Press  or  select the parameter to be adjusted
4		Exit the parameter adjustment by pressing the button,  return to the submenu, and press the button  back to the main menu to select other cams 2 Three steps.
5		Set the parameters to complete, press the button  to exit the setting under the main menu, and the system will automatically save the setting data.

The following is an example of the setting process for setting the F05 trimable cam parameter:

Set the F05 parameter to:

starting Angle = 90 degrees (bbb)

Ending Angle = 270 degrees (ccc)

Cut count = 15 (ddd)

- (1) When the device is idle, hold and key  $\leftarrow$  and  $\rightarrow$  for more than 3 seconds to enter the setting state of the controller. At this time, the three-digit display above will flash, and then use the key  $\rightarrow$  to select F05 and press  $\rightarrow$  to enter the sub-menu.
- (2) At this time, the starting Angle (bbb) of the sub-menu flashes. Press  $\rightarrow$  Enter to enter the adjustment. At this  $\rightarrow$ time $\rightarrow$ , the starting Angle value on the right side will flash. Use the  $\leftarrow$  or  $\rightarrow$  key to adjust the parameter and hold it down  $\rightarrow$  Or  $\rightarrow$  the key value will change quickly. Adjust the  $\rightarrow$ value to 90, and the key  $\rightarrow$  returns to the submenu.
- (3) At this point, the starting angle (bbb) of the sub-menu flashes. Use the left or right arrow keys  $\leftarrow$   $\rightarrow$  to select a sub-menu item and adjust it to the ending angle (ccc), which also flashes. Press  $\rightarrow$  the enter key to adjust the settings. The starting angle value on the right side will then flash. Use the  $\leftarrow$  or  $\rightarrow$  arrow keys to adjust the parameters. Long-pressing the  $\leftarrow$  or  $\rightarrow$  arrow keys will cause the values to change rapidly. Adjust the value to 270. Press  $\rightarrow$  the back button to return to the sub-menu
- (4) At this time, the sub-menu flashes. Use the  $\leftarrow$  or  $\rightarrow$  key to select the sub-menu item and turn to the cropping count (ddd) flashing. Press  $\rightarrow$  enter to enter the adjustment. At this time, the value of the starting Angle on the right side will flash. Use the  $\leftarrow$  or  $\rightarrow$  key to adjust the parameter. Long press the  $\leftarrow$  or  $\rightarrow$  key to change the value quickly. Turn the value to 15. Press the button  $\rightarrow$  to return to the sub-menu.
- (5) Under the sub-menu, press the button  $\rightarrow$  to return to the main menu. Press the button  $\rightarrow$  again for a long time, the system exits the setting, saves the data automatically, and the setting is completed.

**Reminder: When you adjust the starting angle, the 36 indicator lights on the circumference will dynamically display the range of cam you want to adjust, which is more intuitive.**

#### 4.3.3.2 Production count arrival function setting

- (1) FC in the system menu is the production counting arrival function option.
- (2) Enter the menu FC Settings, use the key to switch the  $\rightarrow$  number of bits of the count value, and then use the or key to adjust the count value. After setting, press confirm and exit automatic save.
- (3) When the count arrives, the brake signal (BR) and FC output are simultaneously counted, and the count value flashes; after 5 seconds, the count is automatically reset to zero, the brake signal (BR) and FC stop output, and the system returns to normal operation.

#### 4.3.3.3 Production count reset function





Hold down  $\rightarrow$  for more than 3 seconds or hold down the white button on the control box for 5 seconds.

#### 4.3.4 Parameter Settings

System parameters are important parameters for the controller to work. They need to be changed only when the system needs debugging. System parameters are password protected.

#### 4.3.4.1 Keyboard function description

##### Operation panel menu

key	name	function
	Increase / up	Used to increase the menu up or value. When adjusting the value, long press this key and the value will increase quickly.
	Reduce / down	Used to reduce the menu down or the value. When adjusting the value, long press this key and the value will decrease quickly.
	Enter/switch	Select the menu and use this key to enter, and use this key to switch when adjusting the content. Long press this key for more than 5 seconds, the counter is reset
	Confirm/exit	Used to exit the Settings or exit submenu.

#### 4.3.4.2 Digital display

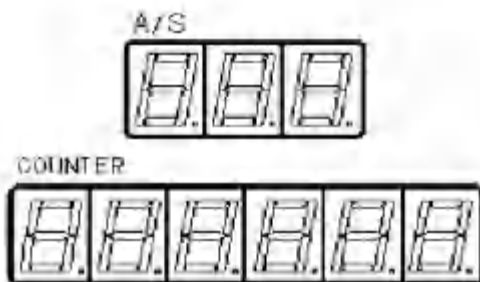

The upper three-digit digital display is used to display the stroke number/angle value: when the stroke is more than 8 times/min in continuous or inch motion mode, the stroke number is displayed; otherwise, the angle value is displayed; in other working modes, the angle value is displayed. The lower six-digit digital display is used to display the working count.

The digital display is used to display a variety of information required by the user. At the same time, in the setting state, the flashing position indicates the current parameter focus, which indicates the location of the user cursor.

#### 4.3.4.3 Enter Settings

When the device is idle, hold and key for more than 3 seconds at the same time, the controller enters the setting state. At this time, the four digits above will flash shine, and use  or again. After the key selection menu, press to enter the submenu.

#### 4.3.4.4 Cam parameter setting

There are 14 sets of cams in total, and F01-F06 are cuttable cams, which can be realized by setting. If they do not need to be used for cutting, they can be used as ordinary cams. Please refer to part 4.3.3.1 for setting, and set the cutting times to 1 to use them as ordinary cams. F07-F12 are ordinary cams.



#### 4.3.4.4.1 F01-F02 The table for the adjustable cam is as follows:

number	Name of the item	unit	Set the scope	Windows default
F01	Open the Angle	Degree	0~359	90
	Close Angle	Degree	0~359	270
	Cut count	Time	2-6000	1
F02	Open the Angle	Degree	360	90
	Close the Angle	Degree	0~359	270
	Cut count	Time	0~359	1
F03	Open the Angle	Degree	2-6000	90
	Close the Angle	Degree	0~359	270
	Cut count	Time	2-6000	1
F04	Open the Angle	Degree	0~359	90
	Close the Angle	Degree	0~359	270
	Cut count	Time	2-6000	1
F05	Open the Angle	Degree	360	90
	Close the Angle	Degree	0~359	270
	Cut count	Time	0~359	1
F06	Open the Angle	Degree	2-6000	90
	Close the Angle	Degree	0~359	270
	Cut count	Time	2-6000	1
F07	Open the Angle	Degree	0~359	135
	Close the Angle	Degree	0~359	250
F08	Open the Angle	Degree	0~359	10
	Close the Angle	Degree	0~359	350
F09	Open the Angle	Degree	0~359	135
	Close the Angle	Degree	0~359	350
F10	Open the Angle	Degree	0~359	180
	Close the Angle	Degree	0~359	350
FC	Generate preset counts	Time	0~999999	0

### 4.3.5 System parameter setting

System parameters are important parameters for the controller to work. They need to be changed only when the system needs debugging. System parameters are password protected.

#### 4.3.5.1 Enter the system menu

- (1) When the device is idle, hold and key  for more than 3 seconds at the same time, and the controller enters the setting state.
- (2) At this time, the three digital displays above will  flash. Then use or key to select the menu, and select P01 in the menu, and press enter menu item.
- (3) Use the  or key to enter the system password, and press the key to return to the main menu.

- (4) At this time, use  the or key to select the menu, and P02, P03,..., P12 will appear in the main menu. Note: Please contact us or the supplier for the system setting password.

#### 4.3.5.2 The system parameter setting table is as follows:

number	Name of the item	Set the scope	Windows default
P02	Direction of rotation is set	0~1	0
P03	180 degree calibration	0~359 degrees	
P05	System parameter view options	0~256	151
P06	Fixed brake angle option	0~359 degrees	0
P07	Disable brake data option	0~1	0
P08	Stop counting or set the protection function for slip and break shaft of coupling	See 5.5.8	0
P09	Communication function Settings	1~32	1
P10	Restore the default parameter option	0~1	0
P11	Number of times the controller is powered on	read only	
P12	Software version number	read only	

#### 4.3.5.3 System menu description

- (1) P02, P03, P06 and P08 are settable parameters in the system menu,
- (2) P05, P07, P09, P10 are system debugging options (do not touch by non-professionals)
- (3) P11 and P12 are read-only options.

#### 4.3.5.4 Set the rotation direction P02

When the crankshaft rotates in a direction inconsistent with the direction indicated by the controller after installing the controller, reset the direction value in P02 menu. The specific method is as follows:

- (1) Use the method in 5.5.1 to enter the system menu.
- (2) At this time, the three digital displays above will  flash. Then use or key to select the menu, and select P02 in the menu, and press enter menu item.
- (3) Use the  key to select 0 or 1. Note: If the rotation direction of the crankshaft is not consistent with the direction indicated by the controller, if the original value is 0, select 1; if the original value is 1, select 0. Press the key to return to the main menu. Then press the key to exit the setting, and the system will automatically save the data. The setting is completed.

#### 4.3.5.5 Controller 180 degree calibration P03

The installation position of the sensor used in the controller does not completely correspond to the specific position of the crankshaft, and generally 180 degrees (bottom dead center) calibration is required.

The press is generally calibrated at 180 degrees. The specific method is as follows: Select the press to work in the inch motion mode, and adjust the press slider to the lowest point (180 degrees) by using the point motion mode.

- (1) Use the method in 5.5.1 to enter the system menu.

- (2) At this time, the three digital displays above will  flash. Then use or key to select the menu, and select P03 in the menu, and press enter menu item.
- (3) At this time, the 180 display will appear and flash. After pressing the button, the 180 will stop flashing.
- (4) Long press the key to exit the setting, the system will automatically save the data, and the setting is completed.

#### 4.3.5.6 Counting point setting

The counting point Angle of the job counter is set by the system to 135 degrees (customizable)

#### 4.3.5.7 Fixed brake Angle Option P06

When set to 0, the automatic brake is activated; when set to 1~359 degrees, the controller will activate the brake at the set angle.

#### 4.3.5.8 Pause counting or shaft break protection

Function option P08 This function needs to be used in conjunction with input signal I4.

- (1) When the sub-menu P81 is entered and set to 0, the pause counting function is enabled. At this time, when there is an input signal I4, the production count pauses counting. (P81 is default 0)
- (2) Turn on the enable flag, set the installation position of the external proximity switch, set the Angle range, at this time the shaft break protection function is enabled, for example: b1. Enter sub-menu P81, set to 1 (enable flag), B2. Enter P82 to set the external hardware detection point Angle (0~359 degrees), Set P82=350 (installation position of external proximity switch); B3. Enter P83 to set the external hardware detection point Angle range ( $\pm 60$  degrees), and set P83=30.
- (3) In single working mode, when the I4 input signal lasts during the set Angle range, it indicates that the machine tool sensor and crankshaft are connected normally; otherwise, the controller reports E13 (driving shaft slipping or broken shaft fault) and outputs a brake signal.

### 4.4 Electronic cam protection and alarm processing

#### 4.4.1 Protection and alarm description

If the controller detects an abnormality during self-test or operation, it will immediately shut down the system to prepare for the signal and output the brake signal, and the system displays the relevant code of the abnormality.

#### 4.4.2 Protection and Fault Code Table:

Code	Name of the item	Anomaly reason	Elimination method
Display flashes	System exception	CPU, memory or display cable is damaged	Change the host or display cable
E06	The sensor is abnormal	Abnormal or damaged wiring	Check sensors and cables
E10	Abnormal alarm	No running signal but angular rotation	Check control signals and related wire connections
E11	The system is unresponsive	The connection between the crankshaft and the sensor is abnormal	Check the drive shaft, coupling, etc

E12	The signal is abnormal	Angle signal is abnormal	Check cable connections
E13	Report broken shaft	The connection between the crankshaft and the sensor slips or breaks	Check the connection between the drive shaft and the coupling

Note: When an alarm occurs, please first clear the cause of the alarm, and then use the reset input signal (usually there is a reset button on the control panel) to clear the alarm display.

Warning: The electronic cam controller is a precision control device. Do not plug or unplug the interface with power to prevent damage.

## 4.5 Operation panel indicator light description

### 4.5.1 See the schematic diagram of the operation panel in 3.1 for instructions

The green indicator light in the panel indicates that the main air switch of the power supply is open, the white indicator light indicates the use of the indicator light, and the yellow or orange indicator light indicates that the system does not have the conditions for slider action. If there is a red indicator light, it means warning or prohibition.

### 4.5.2 [Power Supply]

The power indicator light is on, indicating that the external power has been introduced into the machine electrical box and the air switch has been placed on "ON" to complete the power supply.

### 4.5.3 [Air pressure]

The air pressure indicator light indicates whether the compressed air source can meet the operating conditions of the machine. If it is on, it meets the conditions.

### 4.5.4 [Upper dead point]

The indicator light is used to check whether the slider stops in the upper dead point area when the slider stops running. In the An Yi or continuous mode, before the machine action, the light is on to indicate that the crankshaft Angle is in the "upper dead point" and the slider can run.

### 4.5.5 [Overload]

The light is on to indicate that the hydraulic overload protection device of the punch press has been in effect or that the detection switch for this function is faulty.

### 4.5.6 [PAC Abnormality]

When the light is on, it indicates that there is a problem with the electronic cam in front of the punch press or a fault occurs in the circuit from the back of the electronic cam to the PLC.

### 4.5.7 [Abnormal operation]

When the machine control system does not have the conditions for normal operation, the indicator light will be on to remind the operator to deal with the current problem. After that, the indicator light will be automatically or manually reset by pressing the reset button before the actuator slider can be operated.

#### 4.5.8 [Wrong delivery]

When the light is on, it indicates that the function is misdelivered. Class A (always open) false detection:

Judgment condition: when the switch is selected (normally open) by mistake, it will be detected. As long as there is one signal input, it will be normal; otherwise, an alarm will be immediately raised: the detection of error by mistake and the action will be stopped.

Class B (normally closed) false detection:

Judgment condition: when the switch is selected (normally closed), it will be detected. If there is no primary signal input, it will be normal; otherwise, an alarm will be immediately raised: the detection of misdelivery is abnormal, and the action will be stopped.

#### 4.5.9 [Too low speed]

When the indicator light flashes, it is used to remind the operator that the current running speed of the slider is too slow, which may affect the normal operation of the press. The stamping speed of the press should be appropriately increased to achieve a better stamping speed.

#### 4.5.10 [Abnormal lubrication]

When the system is equipped with an electric grease lubrication device, if the lubrication conditions are met and the oil pump cannot detect a signal change from the detection point on the distribution valve during the operation of the system, the light will be lit to indicate that the operator or equipment maintainer should pay attention to check whether the lubrication is normal to ensure that the mechanical parts can be fully lubricated.

### 4.6 Selection of operation mode

The running mode of the press can be selected by multiple segment selection switches to "inch motion", "safety one stroke", "continuous motion" and other running modes.

- (1) Inch motion: When operated by hand or foot, the slider will move when the operation button is pressed, and it will stop immediately when the hand or foot is released stop.
- (2) Note: Inch operation is set for mold testing, adjustment, trial operation, etc., and should be avoided when normal operation of stamping.
- (3) Safe travel: When operating, the starting position of the slider should be at the upper dead point (0 degrees). Between 00 and 1800, the slider is operated inch by inch. Between 1800 and 3600, the slider stops at the upper dead point when the operation button is pressed.
- (4) Continuous: When pressing the operation button or foot pedal switch, press the slider continuously for 5 seconds before releasing it. If you release the button before 5 seconds, the continuous action cannot be achieved and you need to operate again. To stop, press the continuous stop button on the control panel with both hands, and the slider will stop at the upper dead point.

#### warn:

- (1) For safety, the starting position of the slider is all from the upper dead point. If the stopping position of the slider is not in the upper dead point (0 degree)  $\pm 300$ , at this time, press the operation button, the slider cannot be operated, and the slider must be moved up to the upper dead point position by inch operation, and then continue to operate.
- (2) After the operation mode is selected, the multi-stage selection switch must be locked, the key must be removed, and it must be kept by a special person.

- (3) Before the operation of the press, it should be confirmed that the operation mode is selected in the correct position, such as "inch motion", and check whether it is in the inch motion position.

#### 4.7 Emergency stop button

When the press is running, no matter where the slider is, when the emergency stop button is pressed, the slider will stop immediately and reset according to the button gently turn the arrow direction marked above and press the reset button to continue operation.

**warn:**

- (1) When the work is suspended or the machine is checked, in order to prevent wrong action, the emergency stop button must be pressed and the operation switched.
- (2) Customer's own electrical circuit or parts, if they need to connect with the electrical circuit system of this equipment, should be approved in writing by the Company for safety reasons.

#### 4.8 Pre-start inspection and preparation

- (1) Understand the operation instructions of the press
- (2) Read the control data and slider cycle process in the instruction manual first, and of course understand the meaning of each control switch.
- (3) Check all operational adjustments
- (4) To understand the adjustment indication of the height of the slider and the size of the air pressure, do not change the adjustment arbitrarily, such as the setting of the pressure plate, the tightness of the V-belt and the lubrication device.
- (5) Inspection of auxiliary devices
- (6) The auxiliary device is used to assist the press to produce special functions. Before starting, it should be checked in detail whether it has been assembled according to the regulations.
- (7) Lubrication system inspection
- (8) Before starting, don't forget to check whether each fueling place has been fully lubricated according to the regulations.
- (9) Air compression parts: the automatic spray oiling device (Oiler) should be filled with oil and the oil quantity should be kept at a certain level.
- (10) Pay attention to the fixing of screws, such as flywheel, brake part, guide path and other fixing screws or adjustment screws, control box wire joint screws and other parts of the screws should be fixed properly.
- (11) After adjustment and before operation, pay attention to the placement of small parts and hand tools. Do not place them on the workbench or under the slider surface to avoid blockage. In particular, the placement of screws, nuts, wrenches, screwdrivers and pliers and other daily tools should be paid special attention to put them in the toolbox or a certain position.
- (12) Airsource when the air pressure reaches 4-5.5kg/cm<sup>2</sup>, pay attention to whether there is any leakage in the joints of each duct.
- (13) Turn on the power supply and the power supply indicator light will be on. (Make sure that the O.L.P overload indicator light is not on)
- (14) Test the operation of the clutch and brake by pressing the inch button to see if it is normal.
- (15) Check and prepare before braking.

## 4.9 Operation method

- (1) The circuit breaker is set to "ON".
- (2) When the lock switch is set to 'ON' and the air pressure supply reaches the preset value, the load indicator light will illuminate. If the slider stops at the upper dead center, the overload indicator light will turn off after a few seconds. If the slider stops at any other position, refer to the overload reset procedure to reset the slider to the upper dead center.
- (3) Set the operation mode switch to 'OFF', then press the 'Main Motor Operation' button. The motor will start running. If the motor is started directly, the motor operation indicator light will turn on immediately. If the motor is started in a  $\Delta$  mode, wait for a few seconds until the motor transitions from operation to  $\Delta$  mode, after which the motor operation indicator light will turn on. To stop the motor, press the 'Main Motor Stop' button.
- (4) Test whether the emergency stop circuit is normal. Press the large red emergency stop button on the operation box, and the emergency stop indicator light will be lit. The reset method can be rotated according to the "RESET" rotation direction on the large red button, and the emergency stop light will be extinguished.
- (5) When operating, you must press two large green buttons on the operation panel at the same time (the time difference is not more than 0.5 seconds) for the machine to move.
- (6) When the operation mode selection switch is placed in "inch motion", press the operation button, and the punch press will start to run. When released, the punch press will stop immediately.
- (7) When the operation mode selection switch is placed in "safe one stroke", press the operation button, and the slider moves down similar to the inch motion. However, after 1800, the punch press continues to run to the dead point and stops when the release button is released. (This operation mode should be used when feeding manually to ensure safe operation).
- (8) When the operation mode selection switch is placed in "one stroke", press the operation twist and release it, then the slider completes one up and down stroke and stops at the upper dead point.
- (9) If you want to stop the continuous operation, press the "continuous stop" button and the slider will stop at the upper dead point.
- (10) When the press is running and the red "emergency stop" button is pressed, the slider stops immediately.
- (11) When punching products, the output is pre-calculated. The counter selection switch can be placed in "ON" to accumulate the count. After pressing the white reset button for 5 seconds, the counter will be reset to zero.
- (12) Operation method of overload device: please refer to O.L.P for operation preparation and implementation.
- (13) Special accessories:
  - Ejection Device When the punch press is in operation, placing this selector switch in "ON" mode allows air to be ejected at a certain angle during the operation of the punch press for the discharge of finished products or scrap. The ejection angle can be adjusted by the cam controller inside the cam box.
  - Photoelectric device 1 If there is a photoelectric safety switch, the switch will be placed in "ON" to perform photoelectric safety protection action
  - Misfeed detection typically features two sockets. One socket is designated for mold guide pin detection, which is determined by the mold design. When set to 'ON,' if there is a feeding error, the red light for misfeed detection will illuminate, and the press will stop moving. Once the misfeed fault is resolved, switch the

selection switch from 'OFF' to 'ON,' and the red light will turn off, completing the reset process.

- Electric slide adjustment: When the slide adjustment switch is set to "ON", an emergency stop will be triggered, and the red light will illuminate. Press the up or down button on the slide to adjust its position within the preset range. (Note: When making adjustments, pay attention to the height of the feeding device.)

#### 4.10 Operation selection

- (1) Linked operation: suitable for automatic feeding or continuous operation.
- (2) Inch operation: suitable for trial run and mold use.
- (3) Safe travel operation: This is suitable for the first trial run (after the mold test). When the slider intermittently descends in inch increments, if any unexpected issues arise, the slider can be stopped at any position before the lower dead center. Once the issue is resolved, release the button switch to allow the slider to automatically rise and stop at the upper dead center.
- (4) Before starting the motor, the function of the clutch and brake should be tested to be normal first, and the tools, sliders and platforms should be cleaned up before starting the formal operation.
- (5) Pay special attention to the pre-driving inspection and daily maintenance inspection before formal operation.

**Note:** There is no "safety stroke" device for a press above 200SPM

#### 4.11 Machine shutdown sequence

- (1) The slider stops at the upper dead point.
- (2) All switches stop at the normal position and the switching switch is cut in (OFF) position.
- (3) Cut the motor switch.
- (4) Cut off the power switch.
- (5) Cut off the main power switch.
- (6) After stopping, wipe the workbench and the bottom of the slider and the mold clean and apply a little oil.
- (7) Air compressor (when used independently) turn off the power supply.
- (8) HExhaust of gas storage tank.
- (9) OK.

#### 4.12 Precautions

In order to enable the machine to continuously produce for your factory, please pay special attention to the following points:

- (1) When starting the machine every day, please pay attention to the start-up inspection first.
- (2) Please pay attention to whether the lubrication system of each part is smooth.
- (3) Keep the air pressure between 5.5kg/cm<sup>2</sup> for use.
- (4) After each adjustment (pressure reducing valve and stop valve), special attention should be paid to closing it tightly.
- (5) The wiring of the electrical wiring will not be changed. Do not dismantle or install the wiring privately if there is any abnormal situation. Please check and use according to the electrical wiring diagram.
- (6) The air pressure device oil sprayer (oiler) is often kept full of oil to avoid electromagnetic valve or other faults.
- (7) Check whether the brake and clutch actuation is normal.
- (8) Check whether the screws and nuts of each part are firmly fixed.

- (9) IPunch press is one of the forging and pressing machinery, whose force is very fast and fierce. Operators should not be impetuous or operate with a tired body and mind. If you work for a period of time in a dry and simple operation, your actions are easy to get used to and it is difficult to concentrate. Please stop for a while, take a deep breath and continue to operate.
- (10) When implementing the slider adjustment, pay special attention to adjust the feeding rod of the feeding device to the highest point to prevent the slider from running into the feeding device and causing damage to the machine.

Note: When placed in the "safe stroke" operation, if the punch stroke is completed, stop again within 0.2 seconds at the upper dead point.

**Pressing the button may cause the second light to be turned on. This is normal, as long as you press the reset button. Note: there is no such device above 200SPM.**

## 5. Select accessories to adjust the operation

### 5.1 Manual procedures

- ① Mold height indicator
- ② Gear shaft
- ③ Fixing seat
- ④ Adjust the screws

#### Manual slider adjustment

- (1) First, loosen the fixed screw ④
- (2) Pick up the ratchet handle and put it on the adjustment rod ② of the slider as shown
- (3) To raise the slider, rotate it to the right; to lower the slider
- (4) Then rotate to the left.
- (5) The correct height of the slider (minimum unit 0.1mm) can be seen from the mold height indicator ①.
- (6) According to the above steps, the adjustment procedure can be completed. Special notes:
- (7) When adjusting the slider, please first find out the upper and lower limits of the mold height, and do not exceed the specified upper and lower limits.

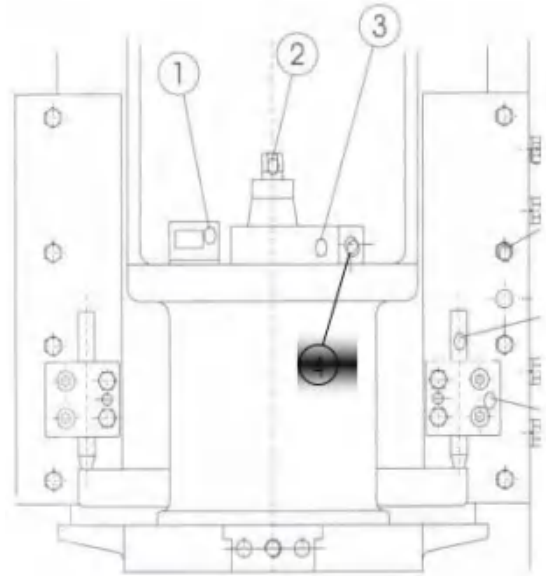

### 5.2 Electromotive force slider adjustment (A80-A260)

- ① Adjust the motor with the slider
- ② Mold height indicator
- ③ knockout plate

#### Electric slider adjustment steps

- (1) Switch the toggle switch on the control panel to the "ON" position.
- (2) If you want to rise, press the operation panel on the rise; if you want to fall, press the operation panel on the fall; release the button switch to adjust and stop immediately.
- (3) When adjusting the slider, the degree can be known by the mold height indicator ② in front of the slider, and the accuracy of the indicator is 0.1mm.
- (4) When the slider is adjusted to the upper limit or lower limit, the microswitch in the indicator is activated and the adjustment stops automatically immediately.
- (5) Switch the switch to the cut position after adjustment.

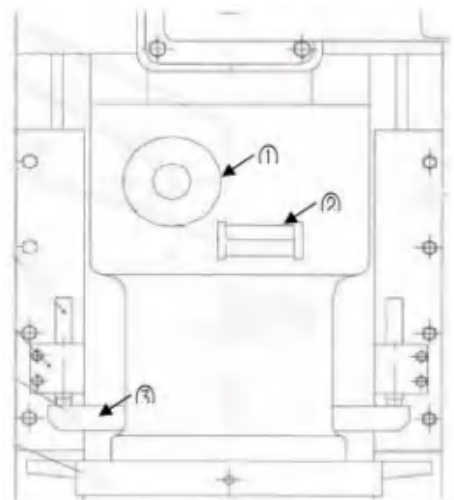

### Precautions

- (1) Before adjusting the height of the slider, please adjust the feeding rod to the highest level to prevent it from being hit by other parts when adjusting the mold height.
- (2) In order to reduce the adjustment force of the slider, please adjust the air pressure in the balancer moderately before adjustment.

- (3) When adjusting the operation, press the emergency adjustment button and turn the switching switch to the "cut" position to ensure that no accident occurs during the adjustment.

### 5.3 Balance cylinder pressure adjustment

After the upper mold is installed on the slider, adjust the pressure of the balance cylinder according to the "Balance Capacity Table" on the left side of the frame.

Pressure adjustment method:

- (1) Loosen the locking knob on the pressure regulator.
- (2) Compare the pressure value obtained from the "balancer capability table" with the gauge reading to determine the corresponding increase or decrease in the pressure value.
  - When the pressure value is increased, the valve cover can be rotated clockwise slowly.
  - When the pressure value is reduced, rotate the valve cover in the reverse direction slowly. When the pressure drops below the required pressure, depressurize the air tank of the balancer and adjust the pressure of the balancer to the required pressure according the content above.
- (3) When the pressure gauge shown in the "Balancer Capability Table" is consistent with the pressure gauge display, tighten the lock button of the pressure regulating valve. If the display is inconsistent, adjust the pressure to the correct pressure according to the above method.

### 5.4 Maintenance inspection record

#### Maintenance inspection record form

Check date:

Name of press				Date of manufacture			
Type of press				Create numbers			
checkpoint	Content, benchmark	method	judge	checkpoint	Content, benchmark	method	judge
Body	foundation screw	Loose, damaged, rusted	spanner	operating system	pressure gage	Whether the indicator value is damaged	visual
		Displacement, collapse	visual		pressure gage	Action adjustment	It works
	staging	The fixed screw is loose	visual		ensemble	Clutch, brake, balance cylinder, mold pad device	visual
		T-slot and pin hole are deformed and damaged and	visual		pressure switch	Whether it's damaged	visual
		Surface damage, deformation	visual			Operating pressure INOUT	It works
	fuselage	fissure	pigment		Mog high indicator	Whether the model high indication value is the same as the measured value	A ruler
		harm	visual			Whether the chain, sprocket, gear shaft and chain mechanism are in good condition	visual
	take precautions	Whether the function is bad	visual			Chain tension	visual

operating system	against earthquakes installation	harm	visual		Drive institution	Switch on Hands, feet Transfer switch	Whether the switch is damaged	visual		
	Lubricants, greases	Whether the oil tank and grease cylinder contain enough oil	visual			operate switch	Whether the movements are normal and the operation is good	It works		
		Whether there is any debris mixed in the lubricating oil and grease	visual			master gear	Whether the cable joint and cover of the operation table are normal	visual		
		Whether there is any oil leakage in each lubrication part	visual				Wear and cracks in the tooth surface, root and valley of the wheel	visual		
	Grape varieties	The cover of the electrical zero and component is off or damaged	visual			The fixed chain is loose	hammer			
		The gearbox cover is missing or damaged	visual			Ripples on the surface when in operation	dialage			
		Flywheel cover is missing or damaged	visual			flywheel	Strain, fever	tactile sensation		
		The fixed screw is loose or broken	spanner				Ripples on the surface when in operation	dialgage		
	operating system	Swivel Angle Indicator	Indication of the lower dead center position	dialgage			crankshaft	Whether it is bent or not, and how it is bent	dialgage	
			Whether the sprocket, chain, chain and fixed pin are damaged	visual				Abnormal wear and surface damage	visual	
		One stop later	Whether the upper dead center stop is good and whether the angle is deviated	visual			crank axle The Vats	Fix screws, nuts and loosen them	spanner	
		Emergency stop is invalid	Safety one trip _ □ light _ □	Visual Angle Meter				Wear and abnormal wear	visual	
emergency stop Stop device		TL+TS=ms	goniometer		among gear wheel	Grinding wear, damage, cracks	visual			
slider take good care of one's health		total excursion mm	It works			The fixed screw is loose	visual			
drive mechanism	gear shaft	Deformation, bite marks and abnormal wear	visual		Jack shaft	Bending, biting and abnormal wear	visual			
		The chain is loose	hammer			Horizontal movement (within 1mm)	visual			
	pinion	Cracks and wear	visual			The chain is loose	hammer			
Clutch brake	clutch	Action stroke	Cursor scale		slider part	Slider guide clearance	Screw loosening and damage	spanner		
		Fixed screws and nuts fall off	visual			platen	Loose, damaged	visual		

		Whether the wear of the incoming plate is contaminated	visual		Balance air cylinder	grinding out	Damage, loose screws	spanner		
		The wear of the ring gear and clutch pinion and whether the key is loose	visual			T slot, screw hole	Deformation, abnormal wear and crack	visual		
		The clutch piston is used to move and circulate air	tactile sensation			Balance air cylinder	Leakage, damage, loose fixing screws	spanner		
		Clutch spring deformation, damage	visual			Slider feeding fixing seat	Damage, loose fixing screws	spanner		
	Brake	Action stroke		Cursor scale			Slider feeding rod	Damage, loose fixing screws	spanner	
		The fixed screws and nuts are loose		visual			Slider feeding rod	Damage or deformation	visual	
		Whether the wear of the incoming plate is contaminated		visual			Main power motive	Abnormal sound, heat, junction box, fixing screw	spanner	
		Check the wear of brake pinion and sliding tooth position and whether the key is loose		visual			motor-driven engine base	Loosening, damage	visual	
		The brake piston moves and air flows		tactile sensation			electromagnetic valve	Operation, leakage	visual	
							pilot lamp	The bulb is broken	visual	
The slider section	Shaft bearing cover	Cracks, damage, loose fixing screws	hammer		Electrical system	electric relay	Contact and coil are faulty	visual		
	crank copper sheathing	Scratches, wear	visual			attendant's cabinet control cabinet	Internal dirt, foreign matter, damage, loose joints	test bar		
	Crank connecting rod	Cracking, damage and abnormal wear	visual			insulation resist	Motor circuit operation circuit	actual measurement		
		Holes, screws, loose, damaged	visual			ground lead	Damage to shock-absorbing rubber	visual		
	Bulb connecting rod	Wear and deformation of threads and balls	pigment			Lubricating oil pump	Oil quantity, discharge quantity	visual		
		Cracks, thread damage	visual			distribute valve	Pump appearance, damage	spanner		
	Blind nut	Loose screws, cracks	visual				Operation, damage, oil leakage	spanner		
	Press the cover	Cracks and damage	visual							
	ball cup	Abnormal wear and deformation	visual							
Lube oil system	oil feeder	Appearance, damage, oil drop, oil stain	visual		die cushion	die cushion	Smooth movement up and down, air circulation, dirt	It works		
	pipeline	Damage, oil leakage	visual			screw	Whether it is loose, broken or damaged	visual		
	Automatic abnormal protection	Whether the protection function of abnormal oil pressure and oil quantity is good	actual measurement			The rotating surface	Gap value, damage, lubrication conditions	visual		
system	revolve shaft seal	Leakage, damage, wear	visual		oil feed	Pump, tubing, damage	visual			

	filter	Water, debris removal effect, damage, dirt	visual			degree of balance	Quadrilateral accuracy determination	dialage	
	air reservoir air receiver	Whether there is water accumulation or air leakage	visual			Action of each valve	Exhaust, locking mechanism, stroke adjustment	It works	
	Valve line	Appearance damage, air leakage	visual			V leather belt	The wear, tension and type of belt	visual	
accuracy	verticality	baseline value mm measured value mm	dial gage		else	Safe installation	Damage, damage to actuation performance, type	visual	
	depth of parallelism	base line value mm measured value mm	dialgage			Fixation of the parts	Loose, fallen off	spanner	
	flatness	base line value mm measured value mm	dialgage			school assignment place	The level of danger at the site	visual	
	synthesize interval	base line value mm measured value mm	dialage						

Comprehensive judgment	<input type="checkbox"/> 1. Can be used <input type="checkbox"/> 2. Precautions for use (some defects should be repaired) <input type="checkbox"/> 3. Prohibited use (some disadvantages have safety concerns)	judge	√	No abnormalities	/	This was not checked
			△	good	×	Urgently needed repairs
Maintenance Representative:						

**Maintenance and repair records**

Month/day	Maintenance parts	Maintenance method and content

## 6. Security section

### 6.1 To ensure the safety of operators and maintain the operation of the machine, please follow the following precautions

The design of this machine, including its power machinery structure and line control, is based on the safety regulations and standards of advanced countries such as Europe, America, and Japan. It is meticulously designed to ensure the convenience and safety of operators, and the mechanical operation circuits must not be altered arbitrarily. If any changes are made without authorization, our company will not be responsible. The following devices and lines are safety devices:

- (1) Emergency stop device.
  - (2) Motor overload device.
  - (3) Linked prohibition loop configuration.
  - (4) Two-handed operation of the safety circuit configuration.
  - (5) Protection device for low speed.
  - (6) encoder
  - (7) Secondary fall system interlock protection.
  - (8) Overload detection device.
  - (9) Wrong delivery of detection device. (Selected accessories)
  - (10) Photoelectric safety device. (It is not standard configuration and additional cost is required. Customers can choose)
- The daily inspection, start-up inspection and regular inspection items mentioned above must be strictly followed.
  - The person in charge of the operation must carry out the following commencement checks.
    - (1) Move the clutch and brake to test whether their functions are normal.
    - (2) Whether the bolts of crankshaft, flywheel, slider, crank connecting rod and screw are loose.
    - (3) When the operation button (RUN) is pressed during a trip, will the slider stop at the specified position? During operation, if the emergency stop interlock device acts or the emergency stop button is pressed, will the slider stop immediately?
      - After completion, when leaving the post or checking, adjusting and maintaining each part, be sure to turn off the power supply and remove the key of the power switch. At the same time, the keys of all switching switches should also be properly kept by the supervisor or the person in charge designated by the unit.
      - The independent daily maintenance of the press should be carried out by professionals, and the inspection records should be properly kept for reference in the next inspection.
      - When checking or disassembling the air pressure device, the power supply and gas source should be turned off first, and the remaining pressure should be completely released before starting to do it. The connection of the air supply source must be closed with the valve first.
      - In terms of electrical maintenance, it should be inspected, adjusted and repaired by qualified technical personnel in accordance with regulations.
      - Before operating the machine, please refer to the main specifications and working capacity limits of the machine, and do not exceed the capability curve.
      - Before the operation of the press, the operator should read the operating procedures of the machine and confirm the position of relevant switches and buttons
      - When the control circuit of the driving mechanism and safety device of the punch press fails, the punch press cannot operate correctly. Refer to (8. Cause of failure

and troubleshooting) for solution. Otherwise, please notify our company to send personnel for maintenance. Do not modify it privately.

### **6.1.1 Emergency stop device**

Both single and continuous movements have emergency stop routes, which serve as a crucial safety measure. The emergency stop button is red and features a RESET knob. In emergencies or during maintenance, pressing the emergency stop button will quickly halt the slide of the press. To reset the system, simply press the emergency stop button and rotate it in the RESET direction to resolve the emergency situation.

### **6.1.2 Motor overload device**

Before using this machine, ensure that the workload is kept below its nominal capacity to maintain normal operation of the press. If the load exceeds the capacity, the overload protection relay will activate, quickly stopping the motor. This relay serves as a protective device for the motor. The overload relay is typically selected at 1.25 to 1.5 times the rated current when the load is at full capacity.

### **6.1.3 Linked stop circuit device**

When the slide is running continuously, press the linkage stop, change the linkage selection switch, or the speed suddenly becomes too low (600rpm), the punch press stops quickly at the specified position (upper dead point). This device protects the machine life and human safety.

### **6.1.4 Two-handed operation of safety circuit device**

For the safety of the operator, when choosing to operate with both hands, the left and right hands must be pressed simultaneously within 0.5 seconds, and the punch press can move. Otherwise, the hands must be released and the operation must be repeated. The left hand operation, right hand operation and foot pedal operation are not subject to this restriction.

### **6.1.5 Low speed protection device**

When the slider is in operation, if the speed of the press decreases due to improper adjustment of the speed regulator or overloading, a low-speed protection is added to the line to prevent the slider from sticking to the mold. If the speed drops below 600 rpm, the linkage stops, and the indicator light flashes with an IS pulse. If the speed is between 600 and 450 rpm, it can still operate for one stroke; however, if the speed falls below 450 rpm, it will stop immediately, and all actions are prohibited.

### **6.1.6 Overload detection device**

This device is a multi-functional hydraulic overload device, which can stop instantly (1/100 seconds) in the state of overload, and automatically return the slider to the dead point when resetting. This protection device ensures the safety of the die and punch press.

### **6.1.7 Wrong delivery of detection device (selected accessories)**

The misfeed detection system typically includes two sockets: one for mold guide pin detection and the other for corner cutting, depending on the mold design. This safety device is designed to protect the press operation. When the press and feeding machine are in sync, if there is a feeding error, the misfeed detection indicator light will illuminate, causing the press to stop immediately. Once the cause of the mold misfeed is identified, switch the selector switch from 'OFF' to 'ON', and then back to 'OFF'. The red light will then turn off, completing the reset process.

### 6.1.8 Photoelectric safety device (optional parts)

Please refer to the photoelectric safety device manual.

### 6.2 Safe Distance (D)

Location of safety device for two-handed operation

When the slider moves down, relax the switch with both hands. When both hands are still under the slider or in the dangerous area of the die, the press has not stopped, so it is easy to have an accident. Therefore, the installation position of the operating switch is as follows:

Type C punch press

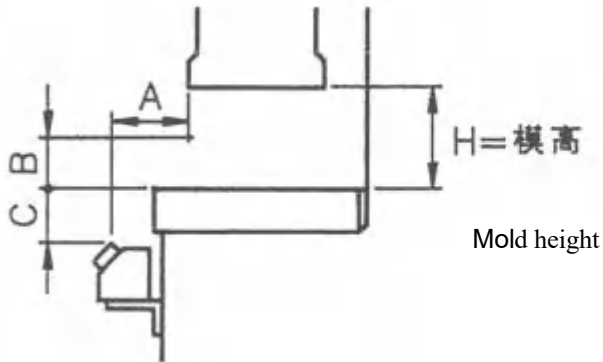

$$A+B+C>D$$

$$B=1/3H \quad (\text{mm})$$

$$D=1.6 \times (Tl+Ts) \quad (\text{mm})$$

$$Tl=15$$

#### Matters need attention:

- (1) This machine is operated by both hands, and its installation position must meet  $A+B+C>D$  and cannot be changed arbitrarily.
- (2) The value of  $Tl$  must be measured every year, and the value of  $D$  and  $A+B+C$  should be compared to ensure its installation position.

#### • The position of the photoelectric safety device

The position of photoelectric safety device and installation position are as follows:

Type C punch press

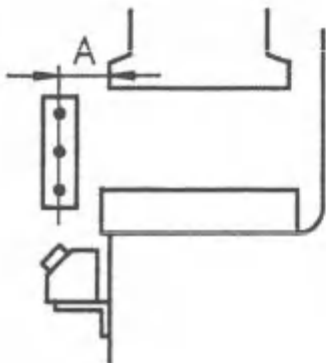

$$A>D$$

$$D=1.6 \times (Tl+Ts) \quad (\text{mm})$$

$$Tl=20 \text{ ms} \quad (\text{以PD型為準})$$

#### Matters need attention:

- (1) The installation position of the photoelectric safety device must be correct and meet the condition of  $A>D$ . The installation position shall not be changed arbitrarily.
- (2) The values of  $Tl+Ts$  must be measured annually and compared with the values of  $A$  and  $D$  to ensure the installation position of the photoelectric device.

## 7. Maintenance

### 7.1 Pressure, electrical and lubrication maintenance

#### 7.1.1 Air pressure:

- (1) Air piping: check whether there is any leakage in each pipeline.
- (2) Air valve and solenoid valve: check whether the control of air valve and solenoid valve is normal under appropriate operation.
- (3) balance cylinder: check for air leakage and proper lubrication.
- (4) mold pad: check whether the air is leaking, check whether there is proper lubrication. Check whether the fixing screws of the mold pad are loose. e pressure gauge: check whether the pointer of the pressure gauge is normal.

#### 7.1.2 Electrical:

- (1) Electrical control: check the condition of the controller and operation response, replace the faulty controller, tighten the loose part. Check whether the fuse is of the appropriate size, check whether the insulation part of the wire is damaged, replace the bad wire.
- (2) Motor: Check whether the fixing screws of the motor and bracket are tightened.
- (3) button and pedal switch: carefully check these switches, if there is a defect, replace immediately.
- (4) Relay (Relay): Careful maintenance should be carried out for the wear of the contact and the loosening or breaking of the wiring.

#### 7.1.3 Lubrication:

- (1) Air lubrication assembly of the A clutch: Eliminate all water, check the condition of the unit (Unit), and fill the lubricating oil to the correct position.



Used for automatic lubrication of double electromagnetic valves and clutches

- (2) Lubrication System: Follow the lubrication points outlined in the lubrication section of this manual for the maintenance of the lubrication system. Check if all lubrication lines are intact, and inspect for any leaks, ruptures, or damage to the components. Ensure that the oil levels in each gauge meet the standard. Under normal operating conditions, the oil-impregnated gear slots should be lubricated every three months, and the oil tanks should be cleaned every six months (approximately 1500 hours).
- (3) workbench: confirm that no foreign matter is placed between the workbench and the rack, confirm that there is no loosening of the workbench locking screws, and confirm that the flatness of the workbench is within the tolerance range.
- (4) clutch: check whether there is any leakage, check the wear of friction plates, etc.
- (5) drive gear: check that the gear and key are tight, and check that the gear is properly lubricated.
- (6) Slide adjustment parts (electric type): Check whether the slide adjustment motor is locked, confirm that the automatic brake is not faulty. Check whether the worm and

worm wheel of the slide adjustment are properly lubricated. Check whether the mold height indicator is accurate.

- (7) slide adjustment parts (manual type): Check whether the gears for slide adjustment are properly lubricated. Check whether the fixator is in failure. Check whether the mold height indicator is accurate.
- (8) motor transmission: check whether the motor shaft and pulley are loose. Check whether the belt and pulley have cracks, wear and deformation.
- (9) Clean: Clean the inside and outside of the press to remove any accumulated foreign matter.

## 7.2 Operation and maintenance precautions:

### 7.2.1 Daily inspection and maintenance points:

It is mainly carried out before and after daily operation, with 10 hours as the standard for each day. If more than 10 hours are exceeded, the operation should be suspended and then checked.

inspection item	Maintenance tips
Pre-operation inspection	
Before the main motor A starts	
1. Whether the oil is fully supplied to each part	Before mechanical operation, the oil in the lubrication system should be filled first. The oil can be filled by pulling the manual button several times with your hand. At the same time, check whether the oil pipe is broken or cut. Pay attention to the manual oil filling parts.
2. Whether the air pressure conforms to the specified pressure	Whether the clutch air pressure (4.0-5.5kg/cm <sup>2</sup> ) is sufficient, attention should be paid to whether the air pressure has changed and must be confirmed again.
3. Check if the pressure regulating valve is abnormal	When air pressure is introduced or the set pressure is changed, it is necessary to confirm whether the secondary pressure conforms to the selected pressure. Occasionally, the selected pressure cannot be controlled due to failure. When the selected pressure (the primary pressure rises) is adjusted, the valve seat must be disassembled and cleaned if there is dust clamped on it.
4. Check whether the action of electromagnetic valves for clutch and brake is abnormal	The clutch is operated by inch movement and the exhaust sound of the solenoid valve is used to identify whether the operation is good or not.
5. Check for air pressure leakage	Check for no air leakage at the pipe joint (such as joints) or clutch cylinder, balancer cylinder, etc. on the right side.
6. Drainage of water in pressure vessels (including balance cylinder)	
After the B main motor starts	
1. Check the condition of the fly cycle	Pay special attention to the starting condition, acceleration condition, vibration and sound (idle for more than 5 seconds). When the rotary resistance increases, the V belt will vibrate.
2. Check of full operation	Before operation, perform full operation confirmation with inch movement, safe travel, continuous operation, emergency stop, and foot pedal operation to check for any abnormality.

### 7.2.2 Weekly maintenance points:

Operation rotation time Maintenance shall be carried out every 60 hours. In addition to the daily inspection and maintenance items mentioned above, the following inspection and maintenance shall be carried out.

inspection item	Maintenance tips
1. Cleaning the air filter	Remove the metal mesh inside the filter (but if there is no serious water accumulation in the piping system in the factory, it can be implemented once every two weeks) When the filter is blocked, the air pressure cannot rise and should be paid attention to.
2. Inspection of electrical components	The looseness of each terminal joint, the attachment of oil and dust, the contact condition of the contact point and other insulation shall be checked and maintained.
3. Confirm that there is no abnormality in the electrical wiring	Check and maintain whether there is any damage, broken wire or loose wiring.
4. Cleaning of all parts	Remove oil, dust, and debris, and check for cracks.



Air filter, used to filter moisture from the air, discharged once a day

### 7.2.3 Monthly maintenance points:

That is, the monthly use time shall be checked and maintained every 260 hours. In addition to the daily and weekly maintenance items, the following checks and maintenance shall be carried out.

inspection item	Maintenance tips
1. Travel measurement of clutch and brake	Check whether the travel of clutch and brake is kept within 0.5mm-1.0mm, and measure and adjust it.
2. Check the tension of the V belt used for the main motor	The V belt is checked by hand for tension. The arc is most ideal when it is about 1/2 "deep in the depression.
3. Check the condition of the inner wall of the balancer cylinder	Check for scratches and lubrication.
4. Confirmation of the stop position at the upper dead point	The upper dead center stop position is unstable for the following reasons. Please adjust according to the situation: 1. Although the stopping position is certain, if it does not match the dead point, adjust the position of the microswitch. 2. The stopping position is not necessarily, but when the error range is small, please adjust the brake stroke. 3. If the stop position is not certain and the error range is too large, please adjust the cam fixing screw or related connection parts.

<b>Inspection in operation</b>	
A. Pay attention to the oil supply state of each part	In operation, please pay attention to the oil supply status at any time. When using the hand pump, pull it several times at any time to avoid oil interruption, which will cause heating and burning of the bearing bush and slider guide plate. The heating is allowed below room temperature +300C. When overheating, stop running. The temperature of the motor shell is limited to below 600C.
B. Pay attention to changes in air pressure	In the operation, pay attention to the pressure gauge frequently and avoid using it beyond the specified pressure to prevent damage to the incoming plate (pay special attention to the decrease of air pressure).
<b>Post-operation inspection</b>	
Cleaning and packing of all parts, as well as comprehensive inspection of the punch press	The air valve should be locked, the dirty water should be discharged and the air cylinder pressure should be released. At the same time, all parts should be cleaned and checked for cracks or damage.

#### 7.2.4 Annual inspection and maintenance points:

Annual maintenance means that the inspection and maintenance shall be carried out every 3000 hours of use. In addition to the above inspection and maintenance items, the following inspection and maintenance shall be carried out. Due to different working conditions, there is considerable wear and damage to each part, so it is necessary to have skilled maintenance personnel or professional service personnel with experience to assist in carrying out thorough inspection and maintenance.

<b>inspection item</b>	<b>Maintenance tips</b>
1. Accuracy check	Slider guide plate gap (0.03mm/m-0.04mm/m) <b>Verticality</b> 0.01+0.01/100 L3 (45Tons and below) 0.02+0.01/100×L3(60-250TONS) <b>Parallelism</b> 0.02+0.06/1000 L2 (45Tons and below) 0.03+0.08/1000×L2 (60-250TONS) comprehensive clearance (0.7mm/m) below (50-250TONS)  Note: L2: Width of slider (front and back, left and right) (mm) L3: Trip length (mm)
2. Disassembly and inspection of clutch and controller	Check and measure the wear amount and condition of the friction sheet, the state of the two sides of the wear plate, the degree of wear of the inner and outer tooth surfaces of the Housing, and the degree of wear of the "P" ring, spring and cylinder inner surface. Repair or replace when defective.
3. Inspection of solenoid valve	The operation condition must be checked, whether the coil is burned or not, and whether the spring is abnormal. If it is bad, please replace it with a new one.
4. Check whether the basic screws are loose	Lock the base screws.
5. Inspection of electrical components	The wear of relay (Relay) contacts, loose wiring and broken wires should be carefully maintained.

## **7.3 Maintenance of electrical parts**

### **7.3.1 Daily maintenance matters**

- (1) Whether the stop position of A punch press is normal.
- (2) Check whether the fixed and clearance of the proximity switch and cam at B point are normal.
- (3) Whether there is any wear or loosening of the transmission mechanism in each part.
- (4) Whether the emergency stop button works properly.

### **7.3.2 Monthly maintenance matters**

#### Stop detection at fixed points with proximity switches and cams

- (1) Check if the fixed screw is loose.
- (2) Whether the distance between the electronic cam and the detection surface of the proximity switch is appropriate.
- (3) Whether there is any water, oil or dust attached to the electronic cam and proximity switch.

#### Use the button switch for operation

- (1) Whether oil and dust are attached to the A contact.
- (2) Whether there is dust and oil attached to the sliding part of B, and whether the movement is smooth.

#### electromagnetic valve

- (1) Whether there is any foreign matter in the coil and exhaust part,
- (2) Check for discoloration of the coil section.
- (3) Check whether the O-rings are damaged and whether the action is smooth.

### **7.3.3 Maintenance matters every six months**

- (1) Check all safety devices to see if they are in action.
- (2) Check whether the B solenoid valve switch is normal.
- (3) Check important relays.
- (4) Check the welding part of the socket.
- (5) Whether the pressure switch part operates normally,
- (6) Check all terminals.

### **7.3.4 Annual maintenance matters**

- (1) During the annual general inspection, the following items should be checked to ensure that they are normal. In order to prevent accidents, it is best to replace them regularly. A important relay (used for running the press and preventing restart).
- (2) Fixed-point stop with proximity switch (or microswitch).
- (3) Microswitches with high frequency of action, etc.
- (4) Operation button, emergency stop button (often used).

### **7.3.5 Other maintenance precautions**

- (1) In addition to the general inspection points of electrical parts mentioned above, a regular inspection should be carried out if accessories are selected.
- (2) Electrical parts are most afraid of dust and oil, and the door must not be opened or removed.
- (3) The parts to be replaced should be fixed well, and the test operation should be carried out first after replacement, and the operation can be carried out only if there is no problem.
- (4) If the mechanical frequency is very high, the above inspection interval time should be shortened. Especially when adjusting the contactor of the motor and running in

inch motion frequently, the contacts are easy to wear out, so special attention should be paid to it.

- (5) The manufacturer of each electrical part has explained its life. In practice, attention should be paid to the frequency of use and the quality of the working environment, and it should be checked and replaced frequently to avoid accidents.

project	life span
solenoid switch	Motor life: 500,000 times (or one year)
button switch	One million times (or one year)
inches switch	20 million times (or two years)
counter	One million times (or two years)
electromagnetic valve	Three million times (or a year)

- (6) The rotary cam switch has been adjusted when it leaves the factory. Please do not adjust it arbitrarily.

### 7.3.6V Replacement of belt type

When the V-belt is damaged, replace it according to the following points:

Move the motor to the side of the flywheel, loosen the belt, and then remove it. When replacing, install all new parts at once. If several old belts are still usable, they should also be removed and replaced, stored as spare parts. Using both new and old belts together can lead to uneven elongation rates, potentially reducing durability. Additionally, even if the nominal lengths of the belts are the same, there may be slight differences in actual dimensions. Therefore, it is essential to carefully select products with consistent lengths.

The standard specifications of the belt are shown in the following table. This specification is applicable to the travel number "V" HZ area. (If the travel number "H" changes and is used in the 60HZ area, the belt specification will also change).

type	15	25	35	45	60	80	110	160	200	260	300
specifications	B-75	B-83	B-92	B-108	B-117	B-130	B-137	B-150	B-171	B-189	B-189

When the tension of the belt is too high, the bearing's lifespan will be shortened, and in severe cases, the shaft may break. Therefore, the tension must be adjusted to ensure the belt has an appropriate degree of slack. At the center point of the belt span, press it with your hand; if the indentation matches the values in the table below, the belt tension is considered acceptable. The belt will take several days to adapt to the groove. After a few days, check the belt and make necessary adjustments to the tension as needed.

When storing the belt, choose a place with less sunlight, heat and moisture, and pay attention to preventing grease from sticking to it.

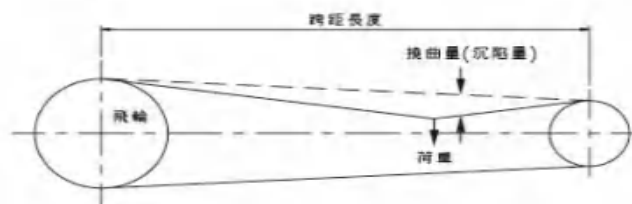

The correspondence between the load and deflection that causes tension in the V-belt is shown in the following table.

Type of belt	Load (approx.)	The deflection corresponding to the span length
A mould	0.8 kilograms	Per meter: 16 mm
B mould	2.0 kg	
C mould	3.5kg	

## 8. Cause and troubleshooting of faults

### 8.1 The upper and lower molds are clamped and released

After the upper and lower molds are clamped, please follow the following methods to disengage.

- (1) The position of the crankshaft must be confirmed before or after the bottom dead point.
- (2) Adjust the air pressure of the clutch to 5.5kg/cm<sup>2</sup>.
- (3) After the slider passes the lower dead point, the motor can rotate in the original direction. If the slider does not pass the lower dead point, the motor reverses.
- (4) Start the motor to drive the pulley to run idle, and then rotate at full speed.
- (5) Switch the operation switch to "inch motion" and press the operation release switch. After several repeated operations, the slider rises to the upper dead point position.

### 8.2 Methods for disengagement of overload safety devices (limited to hydraulic overload safety devices):

- (1) Turn the bolt of the oil circuit of the overload safety protection device in front of the slider to make the oil flow away and reduce the pressure inside, and then fix the bolt in its original position.
- (2) Make the motor start the constant moving pulley idle, and then run at full speed.
- (3) Switch the operation switch to inch motion and press the operation release switch. If the clutch cannot drive the operation, switch the overload switch to the reset position, and repeatedly press the operation release switch to make the slider rise to the upper dead point position.
- (4) After the upper and lower molds are separated, open the stop valve in the piping of the overload device in the same order as the reset operation of the overload safety device, and normal operation can be carried out.

### 8.3 Overload reset by hydraulic pressure

The hydraulic overload safety device is installed inside the slider. Please switch the indicator on the control panel to the normal position.

When the overloading of the press occurs, the oil in the oil pressure chamber is squeezed out and the overloading safety protection state disappears. At the same time, the actuation of the slider also stops automatically. At this time, please reset it in the following order.

- (1) Switch the operation switch to the "inch motion" position, and operate the latch switch to make the slider run to the upper dead point position.
- (2) When the slider rises to the upper dead point position, the overload safety protection device will be restored about one minute later, and the oil pump will stop automatically.
- (3) After the test rotation with inch movement, normal operation can be carried out and the operation guide of the punch press is as follows:

⇒ To release the card, loosen the screw, push the slider to the upper dead point, and lock it when you hear the oil sound.

Press operating guidance:

1. Please loosen this bolt in releasing the mold jam, put the slider to the dead point, and tighten it after hear the voice

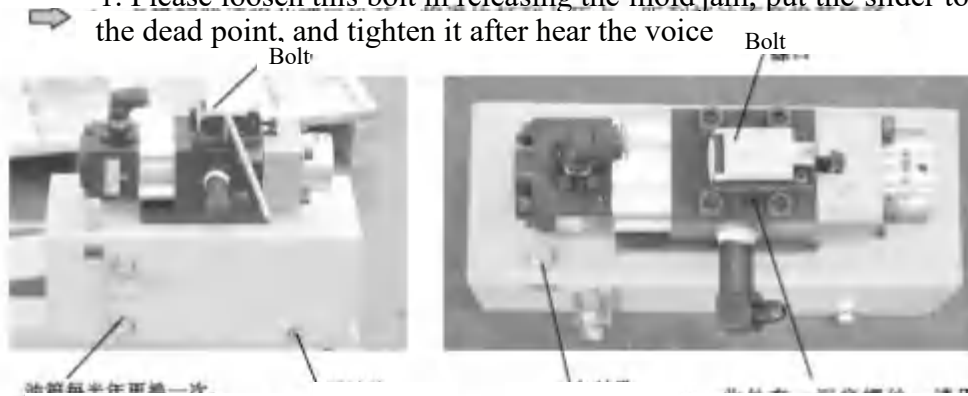

The oil tank should be changed every half year, and add oil to the 1/2 of the oil indicator

Drain

Filling hole

There is a sinking screw here, please loosen it by 6MM hexagon wrench for mold release.

### Fault causes and countermeasures of overload safety protection

phenomenon	Possible reasons	Maintenance method	the way to deal with a situation
pumping unable to work	A. The microswitch used for pump operation is faulty B. The coil of the solenoid valve is open circuit C thermal relay overheats and trips D wiring circuit breaker The E piping parts are faulty, the joint is damaged and air leakage occurs. The F pump itself is faulty	Power on test Power on test Check the setting of the thermal relay Power on test check up manual examination	renewal Renewal Repair or replace the line connection Piping correction Repair or replace
pumping works without stop	Oil level is low Air is mixed into pump B The C overload oil circuit board forces the return of oil D Oil pressure motor steering error E internal O-rings damaged F spring elasticity damage G pump internal oil leakage Oil leakage in H pipe fitting	Check the oil regulations Air removal inspection	Oil supplementation Air removal check up Replace wiring renewal Replacement and repair Accelerate the tightening of replacement
Overload protection does not take effect in case of overload	The proximity switch is misaligned	Check the position of the close switch	Pressure adjustment valve replacement or adjustment

## 9. Lubrication

### 9.1 Lubrication system diagram (electric lubrication system)

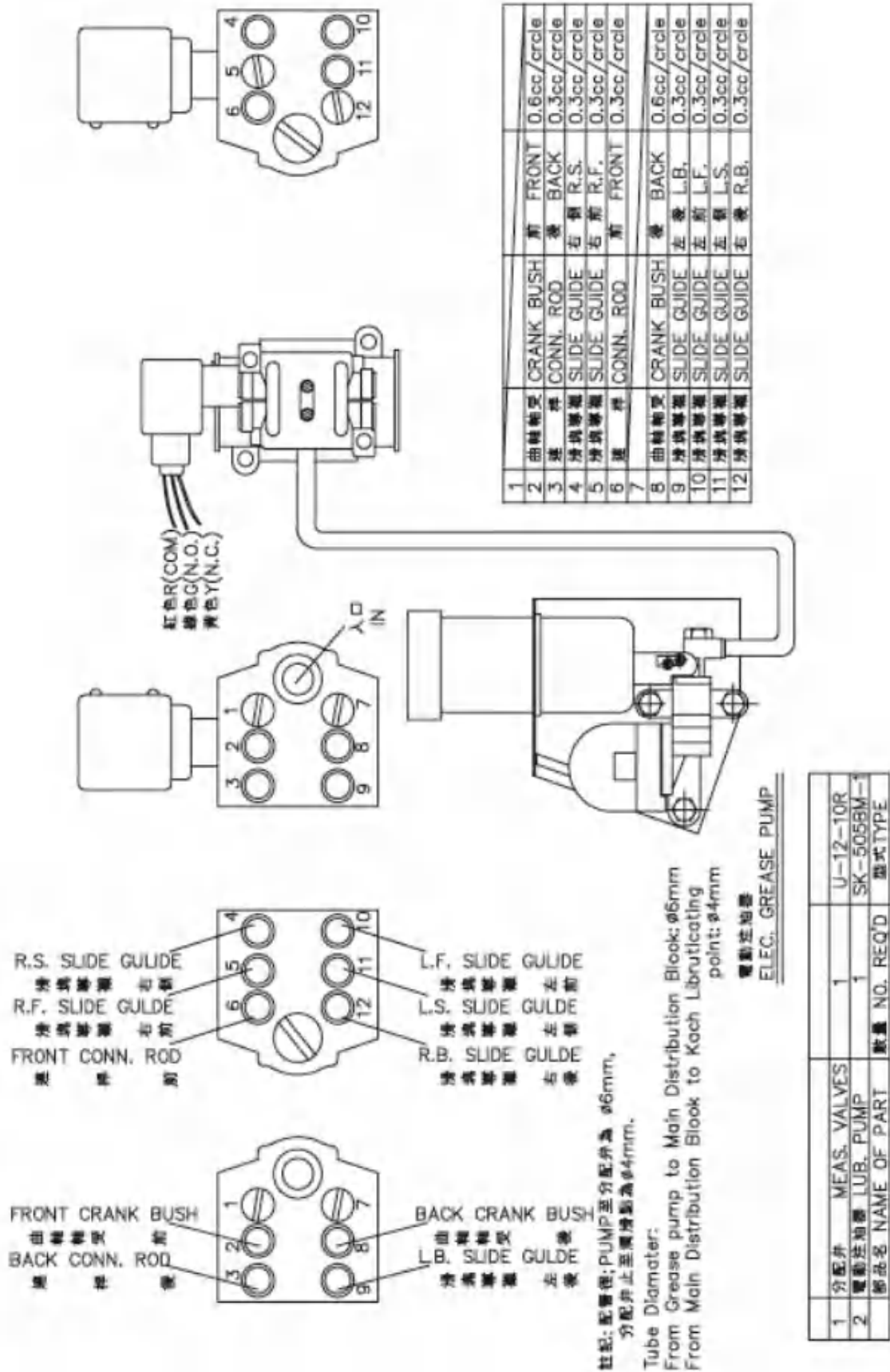

## 9.2 Lubrication system diagram (manual lubrication system)

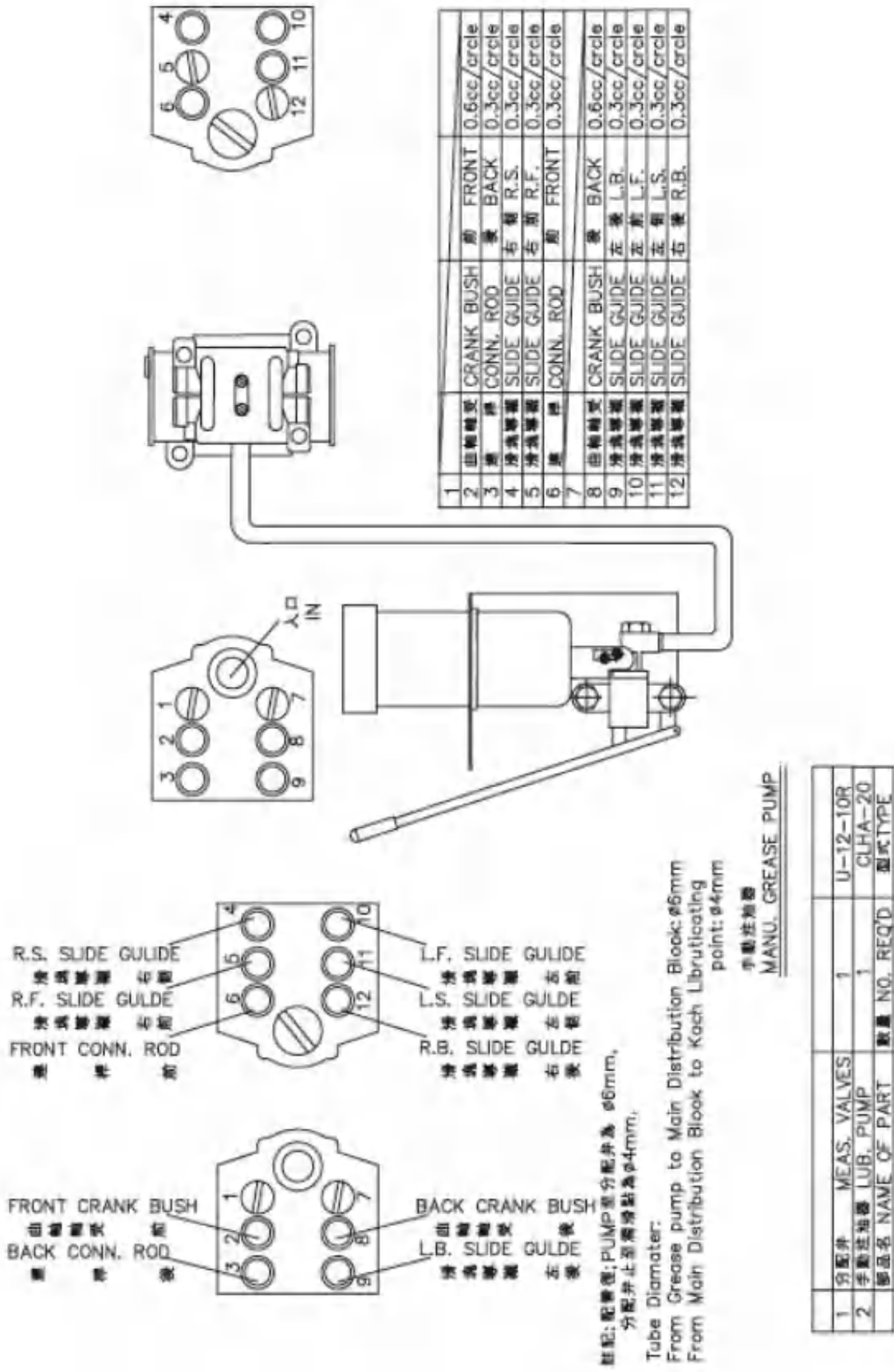

### 9.3 Lubrication instructions

- (1) In operation, please pay attention to adding lubricating grease to the press at any time. Apply grease several times every three hours. Do not cut off the oil to prevent bearing bushings and slider guide plates from heating up and burning out. Heating is allowed below room temperature +30°C. When overheating occurs, stop operation. The motor heating should be limited to the shell temperature below 60°C.
- (2) Maintenance of oil-impregnated gear slot: change the oil every three months, clean the oil tank once every six months (about 1500 hours).
- (3) The bearings of the flywheel and gear shaft are usually lubricated once every two months and checked every six months.
- (4) The balance cylinder system is equipped with a manual oil supply device, which should be inspected every one week and checked every six months.

### 9.4 Oil change cycle

This machine uses grease and oil s lubricating oil.

- (1) Lubricating oil replacement in the gearbox: the oil should be changed once every three months when the machine starts to use, and then every six months thereafter.
- (2) Balance oil supply: check and replenish once a week.
- (3) Flywheel and bearing: this is a closed one, which is also sealed with grease before assembly. The grease should be added once every two months and checked every six months.
- (4) Manual grease oiling device (Greaseoroil): The oil tank of this system is equipped with an oil window through which the amount of oil can be seen. When the oil is insufficient, the lubricating oil is added into the oil tank.

### 9.5 Precautions:

Lubrication and oil change methods should be carried out according to the previous "lubrication overview" for the lubrication system.

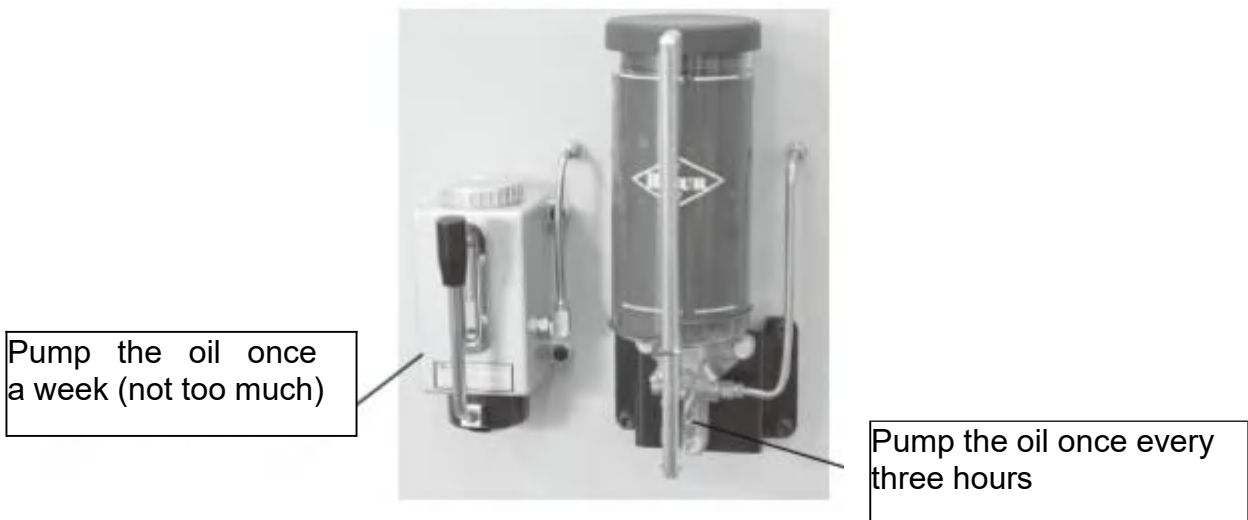

- (1) Lubrication action at the start of work:
  - is lubricated by a manual pump before it can be put into operation.
  - When the operation is stopped for 24 hours and then started again, the manual pump shall be used to lubricate twice as much as usual, and then production can be put into operation.
- (2) Lubricating oil tank:
  - The oil quantity should be checked daily and replenished as required.

- In particular, at the initial installation, the oil quantity in the box may be greatly reduced because of the need to meet the storage requirements of the machine, so attention should be paid.
- (3) Manual oiling:
- A. When manually replenishing oil or applying grease, be sure to turn off the power supply first.
  - B. When applying grease to the chain, check the tension of the chain at the same time and adjust the sprocket weight as required once the new adjustment is in place.
- (4) Replacement of lubricating oil in the gearbox:
- After the mechanical acceptance of A is completed, the lubricating oil in the gearbox shall be replaced once after three months (750 hours) of operation of the new car, and then every six months (1500 hours), and the oil tank shall be cleaned.
  - For the type and quantity of oil B, please refer to <A series of lubricating oils

## 10. Description of forming function of punch press

### 10.1 Standard configuration

#### 10.1.1 Rack:

The structure of the machine is designed by computer aided design, and the strength of the frame and the distribution of load stress are designed in the most reasonable way.

#### 10.1.2 Slider section:

- (1) manual adjustment device: Use manual adjustment device. (A-15-60)
- (2) electric adjustment device:(A-80-400)
  - The disc brake motor is used for button operation, the mechanism is stable, the positioning is accurate, and the adjustment work can be completed quickly.
- (3) model height indicator: actuated with the electric adjustment device, its reading can reach 0.1mm.
- (4) is equipped with a balance cylinder.
  - To withstand the weight of the slider and die, so that the press runs evenly, to ensure the accuracy of the product.
- (5) overload device (also known as card model release device):
  - The multi-functional hydraulic overload device can stop instantly (1/1000 seconds) under the overload state, and automatically return the slider to the dead point when resetting, ensuring the safety of the die and punch press.

#### 10.1.3 Transmission part:

- (1) composite pneumatic friction clutch and clutch brake:
  - The composite pneumatic friction clutch and clutch brake are used to reduce the inertial loss of the passive part and adjust and check easily.
- (2) brake pads:
  - Using super molding brake friction pads, wear resistance is good, can stop in any position instantly, high safety.
- (3) built-in transmission mechanism:
  - The transmission part is completely hidden in the body to improve safety, the transmission gear is immersed in the oil tank to increase the life of the machine and eliminate noise.

#### 10.1.4 Rotary cam control box:

It is easy to adjust on the right side of the press and is indeed a component of automatic control.

#### 10.1.5 Air piping control box:

Air pressure parts such as air pressure regulating valve, lubricator, air filter and air pressure switch are attached under the rack.

#### 10.1.6 Electrical control box:

It is located on the right side of the rack and equipped with emergency stop air pressure confirmation and various safety circuits.

#### 10.1.7 Operation control panel:

Located in front of the rack, equipped with various indicators and control buttons to provide control signals at any time.

## 10.2 Selection of accessories

### 10.2.1 Photoelectric safety device:

If necessary, photoelectric safety devices can also be installed to ensure the safety of operators.

### 10.2.2 Rapid mold changing device:

This machine can be equipped with rapid mold lifting and changing device to reduce your mold lifting and changing time and increase production efficiency.

### 10.2.3 Automatic feeding shaft end:

According to customer's needs, the gear shaft for automatic operation is provided on the left side of the rack to facilitate customer's assembly of automatic feeding device.

### 10.2.4 Mold Pad Device:

When necessary, the mold pad device can be added to improve the efficiency of the press operation.

## 10.3 Slider construction

### 10.3.1 Assembly construction drawing of slider (A-15-60)

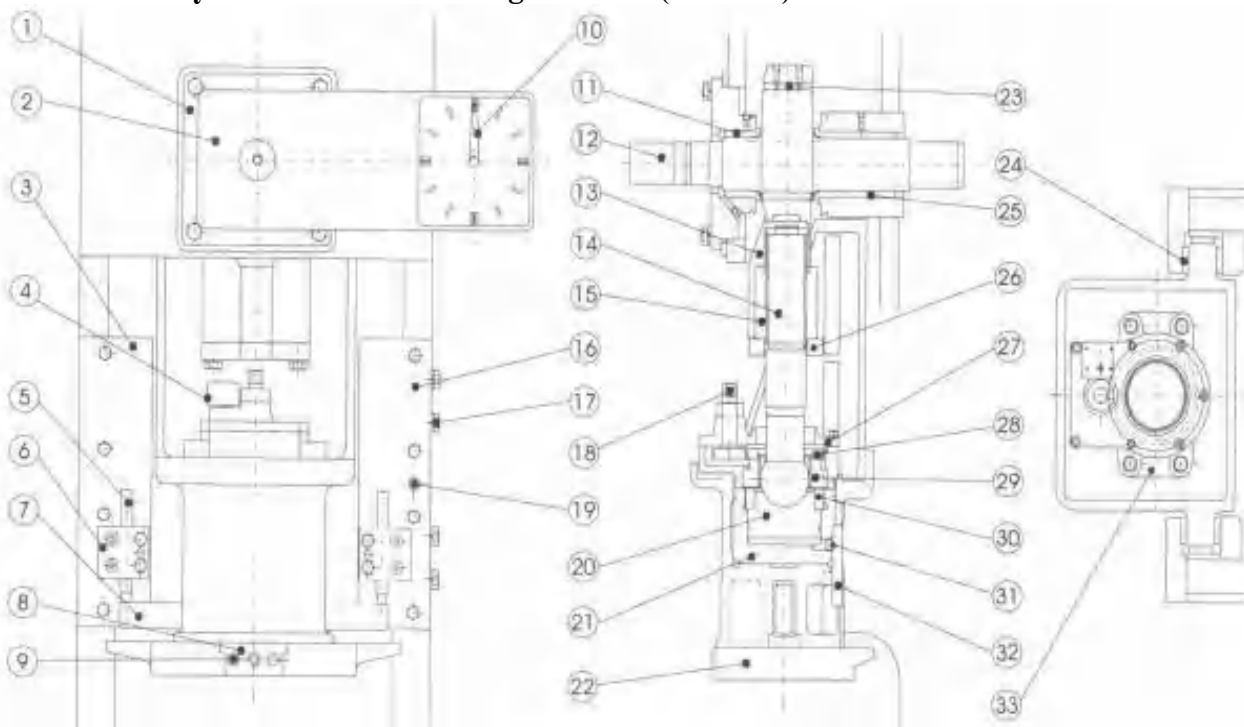

1. Crankshaft bearing seat	12. Crankshaft	23. Crank copper sleeve
2. Cover	13. Crankshaft and connecting rod	24. Copper plates
3. Left pressure plate	14. Connecting rod	25. Rear axle bearing
4. Altitude indicator	15. Adjust the nut	26. Press plate
5. Feed rod	16. Right pressure plate	27. Pressure cover
6. Material support	17. Adjust the screws	28. Modulus gear
7. Material plate	18. Gear shaft	29. Ball head pressure cover

8. Workbench clamps	19. Positioning pin	30. Hydraulic cylinder nut
9. Double-headed screws	20. Ball head seat	31. Joints
10. Indicators	21. Cylinder	32. Fixing seat
11. Front crankshaft bearing	22. Go to the workbench	33. Fix the cover

### 10.3.2 Assembly construction drawing of slider (A-80-400)

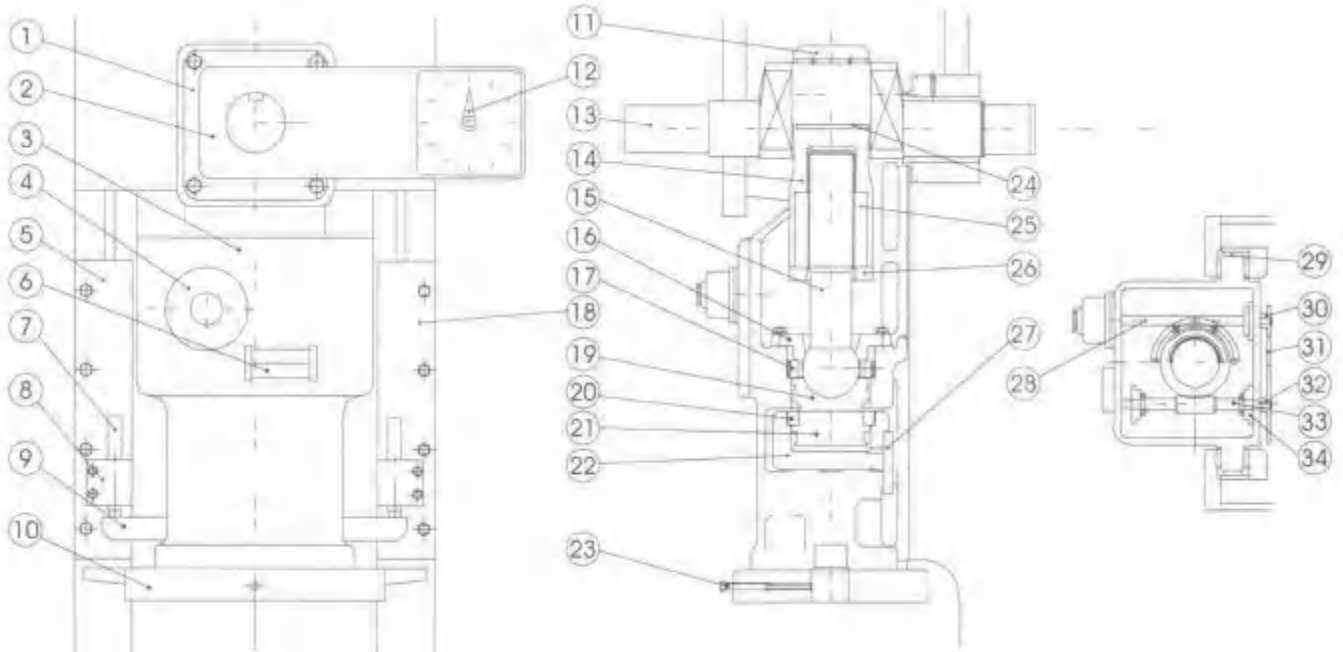

1. Crankshaft bearing seat	13. Crankshaft	25. Adjust the nut
2. Cover	14. Crankshaft and connecting rod	26. Press plate
3. Motor seat	15. Connecting rod	27. Fixing seat
4. Brake motor	16. Ball head pressure cover	28. Motor shaft
5. Left pressure plate	17. Worm wheel	29. Copper plates
6. Altitude indicator	18. Right pressure plate	30. Motor sprocket
7. Feed rod	19. The Ballhead	Chain
8. Fix the material	20. Cylinder nut	32. Chain wheel
9. Material plate	21. Piston	33. Worms
10. Go to the workbench	22. Cylinder	34. Bearing seat
11. Connecting rod cover	23. Clamp top rod	
12. Indicators	24. Crank copper sleeve	

## 10.4 Special devices

### 10.4.1 Mechanical feeding device

Specification: the blanking capacity is based on 5% of the stamping capacity.

Structure:

- (1) It is composed of material striking rod, fixing seat and material striking plate.
- (2) The feeding plate is installed on the center line of the slider.
- (3) When the slider rises, the feeding plate contacts the feeding rod and pushes out the product.

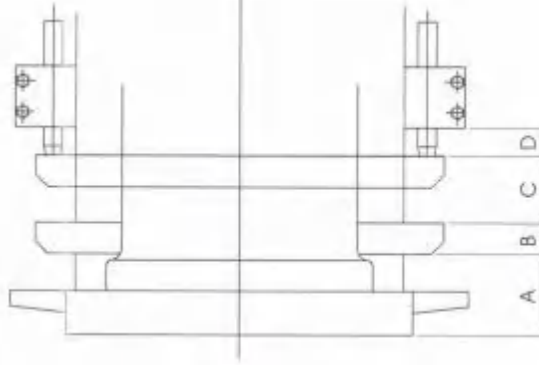

ton	15	25	35	45	60	80	110	160	200	260	315	400
<b>A</b>	75	75	70	90	105	130	140	160	165	175	175	175
<b>B</b>	30	30	35	40	45	50	55	60	80	80	80	80
<b>C</b>	25	25	30	35	35	50	75	85	95	125	125	125
<b>D</b>	20	20	25	25	25	30	30	45	45	45	45	45

The dimensions in the above table indicate that the slider is at the lower dead point when the standard specification is indicated, and the slider is adjusted at the upper limit value.

- (1) Operation and adjustment:

- Loosen the fixing screw of the feeding rod, put the feeding rod at the desired position, and adjust the feeding rod on both sides to the same size.
- Tighten the fixing screw after adjustment.
- When the feeding device is used, some noise will be generated due to the contact between the feeding plate and the slider.

- (2) Second, matters needing attention:

When changing the mold, pay special attention to the height adjustment of the slider. Before adjusting the height of the mold, please adjust the feeding rod to the highest position to prevent it from being hit by other parts when adjusting the height of the mold.

### 10.4.2 Pedal switch device

For safety reasons, it must be used in conjunction with photoelectric safety devices or safety guides. Where not necessary, pedal switches should be avoided whenever possible for safety reasons.

#### method of operation:

- (1) Switch the operation mode to "pedal" position.
- (2) When the pedal is stepped on, the punch can move.
- (3) In the use, special attention should be paid to the operation method of the pedal switch, and the action between the foot and hand should be coordinated to ensure the personal safety of the operator.

### 10.4.3 Hydraulic overload protection

If the press itself is overloaded, it will cause damage to the machinery and the die. In order to prevent this accident, the A type has a hydraulic overload protection device installed inside the slider.

- (1) Type: hydraulic type
- (2) Specification: The maximum stroke of the oil pressure load of the overload oil pump is 10mm.
- (3) Structure:

- 1. Fixed seat
- 2. Fix plate
- 3. Ball head cover
- 4. Nut
- 5. Piston
- 6. Oil cylinder
- 7. The slider
- 8. Crankshaft and connecting rod
- 9. Adjust the nut
- 10. Connecting rod
- 11. Worm wheel
- 12. Ball head seat
- 13. Overload pumping
- 14. Fixing seat
- 15. Overload fixing seat
- 16. Oil chamber
- 17. Go to the workbench

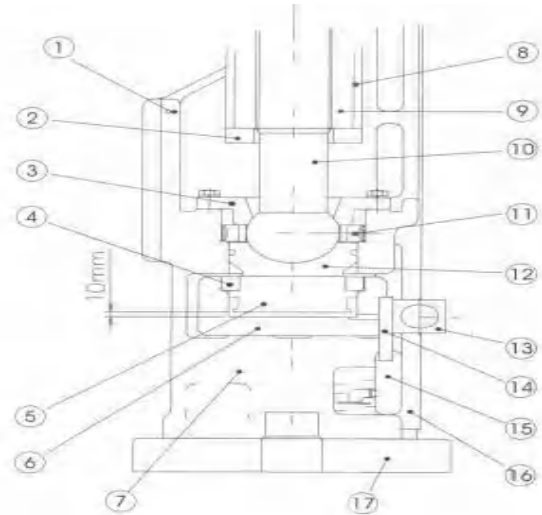

- (4) Operation preparation of overloaded oil pump
  - A. Check the oil quantity and confirm whether the oil quantity is between H.L. If the oil quantity is insufficient, please open the screw of the oil filling port to fill it.
  - B. Confirm that the pressure of the air pressure gauge is normal.
  - C. The power supply of the electrical control panel is turned off and then turned on, and the overload indicator light is lit.
  - D. If the slider stops near the upper dead point, the hydraulic oil pump starts to operate and stops when the set pressure is reached within 1 minute, and the "overload" indicator light goes out at the same time.
  - E. If the slider does not stop near the upper dead point, reset it according to the following methods.
    - 1) The operation mode selection switch is in the "inch motion" position.
    - 2) Press the operation button to run in inch motion and stop the slider at the upper dead point position. (If the mold is installed, please pay attention to the working height of the mold to ensure safety)
    - 3) When the slider reaches near the dead point, the overload oil pump starts to operate, and the oil pump will automatically stop after the set pressure is reached within 1 minute.

- (5) Overload oil pump air discharge

If air is mixed into the oil pump, the overload protection function cannot be fully exerted, and even cause the oil pump to run continuously. Methods to eliminate air:

- A. Stop each slider near the upper dead point.
- B. For safety, after the main motor and other flywheels are completely stationary, reverse the screw of the oil discharge hole of the oil pump device behind the slider with a hex socket wrench. At this time, oil will flow out.

- C. Check the oil flowing out. If it is intermittent or mixed with foam, it indicates that air has been mixed in. Please wait until the oil flowing out is no longer intermittent or mixed with foam, and tighten the screw of the drain hole

(6) Reset of hydraulic overload protection device:

The hydraulic overload safety device is installed inside the slide. Please switch the switch on the control panel to the normal position. When the press is overloaded, the high pressure oil in the overload oil chamber of the slide will return to the overload oil pump, and the action of the slide will be automatically stopped.

At this time, please reset it in the following order:

- (1) Switch the operation switch to the "inch motion" position, and operate the buckle switch to make the slider run to the upper dead point.
- (2) When the slider rises to the upper dead point position, the overload safety protection device will be restored about one minute later, and the oil pump will automatically stop pumping.

## 11. Machine use range and life

- (1) This machine is only suitable for metal punching, bending, drawing and compression forming. Do not use it for other purposes outside the specified scope of application.
- (2) This machine is not suitable for cast iron, wood, glass and ceramic and other brittle materials or magnesium alloy and other easy fuel processing.
- (3) If you want to use materials outside the scope of application above, please contact our sales or service unit.
- (4) Estimate service life:  $8\text{hrs} \times 6\text{Days} \times 50\text{Weeks} \times 10\text{Y} = 24000\text{h}$

## 12. Punching press assembly diagram

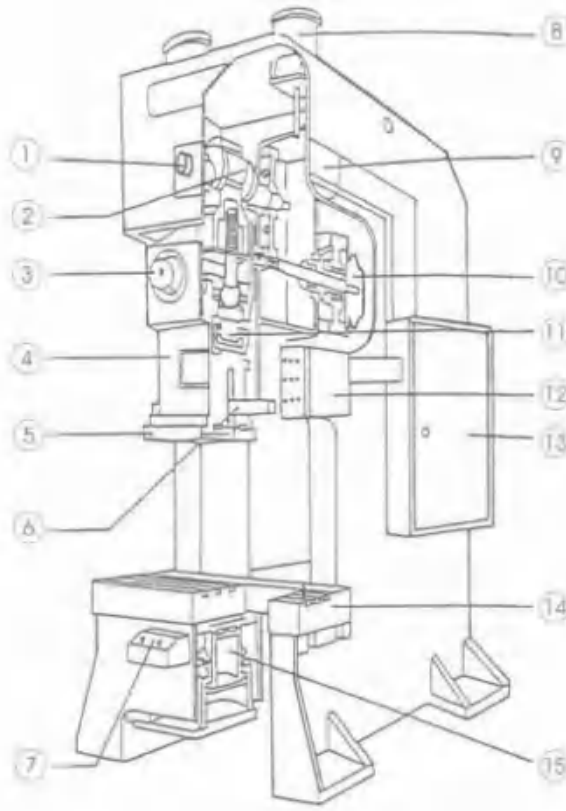

project	name	project	name
1	Shaft end of the feed	9	Cam control box
2	crank axle	10	Clutch brake
3	Slider adjustment device (80-260)	11	Oil pressure overload safety protection device
4	slider	12	main controlling board
5	Go to the workbench	13	Electrical control box
6	knockout plate	14	staging
7	Use the steering wheel with both hands	15	Mold pad (select accessories)
8	balancer		

### 13. Stamping machine specifications and parameters

**MODEL:SYA-25 Press**

<b>Model TYPE</b>	<b>V</b>	<b>H</b>
Pressure capacity TON	25	
Pressure occurring point mm	3.2	1.6
Stroke per minute S.P.M	60-140	130-200
Distance mm	70	30
Max shut height mm	195	215
Slide adjustment mm	50	
Size of the worktable (LR×FB) mm	680×300	
Slide area (LR×FB) mm	300×220	
Die orifice mm	φ 38.1	
Slide surface size mm	240×120	
main motor HP×P	VS 3.7×4	
Slide adjusting device	manual type	
machine weight Kg	2100	

**MODEL: SYA-35 Press**

<b>Model TYPE</b>	<b>V</b>	<b>H</b>
Pressure capacity TON	35	
Pressure occurring point mm	3.2	1.6
Stroke per minute S.P.M	40-120	110-180
Distance mm	70	40
Max shut height mm	220	235
Slide adjustment mm	55	
Size of the worktable (LR×FB) mm	800×400	
Slide area (LR×FB) mm	360×250	
Die orifice mm	φ 38.1	
Slide surface size mm	280×140	
main motor HP×P	VS 3.7×4	
Slide adjusting device	manual type	
machine weight Kg	3000	

**MODEL: SYA-45 Press**

<b>Model TYPE</b>	<b>V</b>	<b>H</b>
Pressure capacity TON	45	
Pressure occurring point mm	3.2	1.6
Stroke per minute S.P.M	40-100	100-150
Distance mm	80	50
Max shut height mm	250	265
Slide adjustment mm	60	
Size of the worktable (LR×FB) mm	850×440	
Slide area (LR×FB) mm	400×300	
Die orifice mm	φ 38.1	
Slide surface size mm	300×150	
main motor HP×P	VS 5.5×4	
Slide adjusting device	manual type	
Using air pressure kg/ cm <sup>2</sup>	6	
Machine weight Kg	3800	

**MODEL: SYA-60 Press**

Model TYPE	V	H
Pressure capacity TON	60	
Pressure occurring point mm	4	2
Stroke per minute S.P.M	35-90	80-120
Distance mm	120	60
Max shut height mm	310	340
Slide adjustment mm	75	
Size of the worktable (LR×FB) mm	900×500	
Slide area (LR×FB) mm	500×360	
Die orifice mm	φ 50	
Slide surface size mm	320×160	
main motor HP×P	VS 5.5×4	
Slide adjusting device	manual type	
Using air pressure kg/ cm <sup>2</sup>	6	
Machine weight Kg	5600	

**MODEL: SYA-80 Press**

Model TYPE	V	H
Pressure capacity TON	80	
Pressure occurring point mm	4	2
Stroke per minute S.P.M	35-80	80-120
Distance mm	150	70
Max shut height mm	340	380
Slide adjustment mm	80	
Size of the worktable (LR×FB) mm	1000×550	
Slide area (LR×FB) mm	560×420	
Die orifice mm	Φ50	
Slide surface size mm	360×180	
main motor HP×P	VS 7.5×4	
Slide adjusting device	electrodynamic type	
Using air pressure kg/ cm <sup>2</sup>	6	
Machine weight Kg	6500	

**MODEL: SYA-110 Press**

Model TYPE	V	H
Pressure capacity TON	110	
Pressure occurring point mm	6	3
Stroke per minute S.P.M	30-60	60-90
Distance mm	180	80
Max shut height mm	360	410
Slide adjustment mm	80	
Size of the worktable (LR×FB) mm	1150×600	
Slide area (LR×FB) mm	650×470	
Die orifice mm	Φ50	
Slide surface size mm	400×200	
main motor HP×P	VS 11×4	
Slide adjusting device	electrodynamic type	
Using air pressure kg/ cm <sup>2</sup>	6	
Machine weight Kg	9600	

**MODEL: SYA-160 Press**

<b>Model TYPE</b>	<b>V</b>	<b>H</b>
Pressure capacity TON	160	
Pressure occurring point mm	6	3
Stroke per minute S.P.M	20-50	40-70
Distance mm	200	90
Max shut height mm	460	510
Slide adjustment mm	100	
Size of the worktable (LR×FB) mm	1250×800	
Slide area (LR×FB) mm	700×550	
Die orifice mm	Φ65	
Slide surface size mm	440×220	
main motor HP×P	VS15×4	
Slide adjusting device	electrodynamic type	
Using air pressure kg/ cm <sup>2</sup>	5	
Machine weight Kg	16100	

**MODEL: SYA-200 Press**

<b>Model TYPE</b>	<b>V</b>	<b>H</b>
Pressure capacity TON	200	
Pressure occurring point mm	6	3
Stroke per minute S.P.M	20-50	50-70
Distance mm	200	100
Max shut height mm	460	510
Slide adjustment mm	110	
Size of the worktable (LR×FB) mm	1400×820	
Slide area (LR×FB) mm	850×630	
Die orifice mm	Φ65	
Slide surface size mm	480×240	
main motor HP×P	VS18×4	
Slide adjusting device	electrodynamic type	
Using air pressure kg/ cm <sup>2</sup>	5	
Machine weight Kg	23000	

**MODEL: SYA-260 Press**

<b>Model TYPE</b>	<b>V</b>	<b>H</b>
Pressure capacity TON	260	
Pressure occurring point mm	7	3.2
Stroke per minute S.P.M	20-40	40-50
Distance mm	250	150
Max shut height mm	500	550
Slide adjustment mm	120	
Size of the worktable (LR×FB) mm	1500×840	
Slide area (LR×FB) mm	950×700	
Die orifice mm	Φ65	
Slide surface size mm	520×260	
main motor HP×P	VS 30×4	
Slide adjusting device	electrodynamic type	
Using air pressure kg/ cm <sup>2</sup>	5	
Machine weight Kg	31800	

## 14. Forging press accuracy requirements

The accuracy of this machine is based on the measurement method of JISB6402 and manufactured with the allowable value of JIS1 level.

type		A-15	A-25	A-35	A-45	A-60	A-80
Flatness of the workbench surface	the left and right sides	0.039	0.039	0.044	0.046	0.052	0.048
	around	0.024	0.024	0.028	0.030	0.034	0.032
Parallelism between the top of the workbench and the bottom surface of the slider	the left and right sides	0.034	0.034	0.039	0.042	0.070	0.050
	around	0.028	0.028	0.030	0.034	0.058	0.039
The verticality of the work table is determined by the up and down movement of the slider	V	0.019	0.019	0.021	0.023	0.048	0.031
	H	0.014	0.014	0.016	0.018	0.036	0.019
	L	0.019	0.019	0.021	0.023	0.048	0.031
Verticality between the slider aperture and the bottom surface of the slider	the left and right sides	0.090	0.090	0.108	0.120	0.168	0.150
	around	0.066	0.066	0.075	0.090	0.126	0.108
Comprehensive gaps	bottom dead centre	0.35	0.35	0.38	0.40	0.47	0.43

type		A-110	A-160	A-200	A-260	A-315	A-400
Flatness of the workbench surface	the left and right sides	0.058	0.062	0.068	0.072	0.078	0.080
	around	0.036	0.044	0.045	0.072	0.080	0.085
The workbench is above and sliding Parallelism of the bottom surface	the left and right sides	0.079	0.083	0.097	0.106	0.106	0.106
	around	0.062	0.070	0.077	0.083	0.083	0.083
The slider moves up and down Verticality on the workbench	V	0.052	0.055	0.055	0.063	0.063	0.063
	H	0.037	0.039	0.040	0.048	0.048	0.048
	L	0.052	0.055	0.055	0.063	0.063	0.063
Verticality between the slider aperture and the bottom surface of the slider	the left and right sides	0.195	0.210	0.255	0.285	0.285	0.285
	around	0.141	0.165	0.189	0.210	0.210	0.210
Comprehensive gaps	bottom dead centre	0.52	0.58	0.62	0.68	0.68	0.68

## 15. Three factors that determine the capacity of a punch press

When using the punch press for operation, the pressure capacity, torque and working ability will never exceed the specification value. If the operation exceeds the specification value, not only the punch press will be damaged, but also there is a danger of personal accident, so we must pay great attention to it.

### 15.1 Pressure capacity

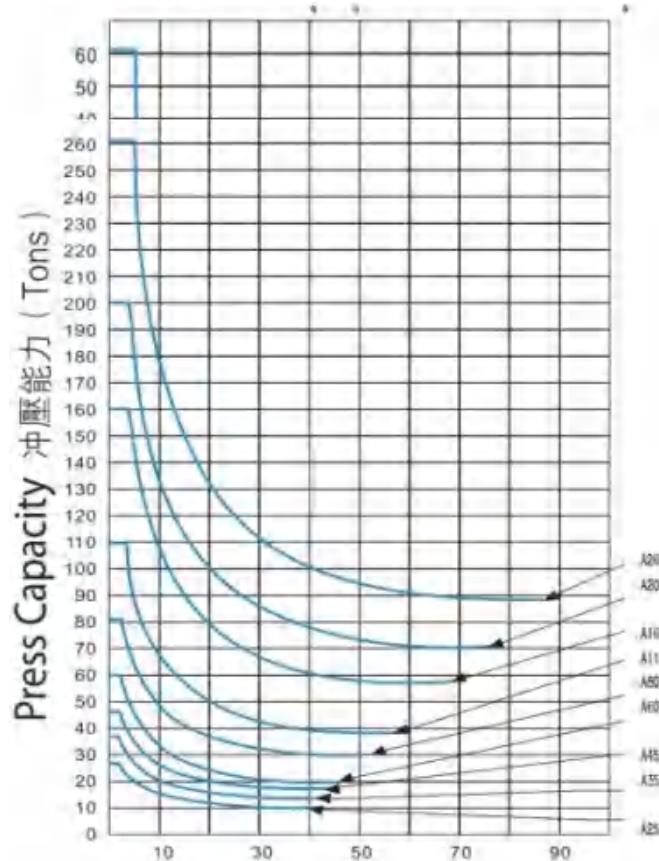

Machine type	25N	35N	45N	60N	80N	110N	160N	200N	260N	315N	400N
route or distance of travel mm	60	70	80	120	150	180	200	200	250	250	250
Capacity point mm	3.2	3.2	3.2	4	4	6	6	6	7	7	7

The so-called "pressing capacity" refers to the maximum allowable pressing capacity below the position where the stamping structure can safely bear the load. However, considering the differences in material thickness, tensile force (hardness), the lubrication state of the die or changes in wear, the pressing capacity must be given a certain margin.

In particular, when the stamping operation is carried out, including the stamping process that may be subjected to impact load due to penetration, the stamping force of the stamping and cutting process must be limited as follows. Limitation of stamping and cutting capacity

A (V) type..... Less than 70% of the pressurization capacity

A (H) type..... Pressure capacity is less than 60%

If the limit value is exceeded, the connection part of the slider and the mechanism may be damaged.

In addition, the pressurization capacity is calculated based on a uniform load over 60% of the central area of the mold seat. Therefore, avoid loading a large load in a small area or eccentric loads where the resultant load deviates from the center. If you must work under extremely severe conditions of concentrated or eccentric loads, please consult the technical department.

## 15.2 Torque capacity

The press's pressure capacity varies according to the slider position. This variation is represented by the "stroke pressure curve". When using this machine, the working load must be less than the pressure shown in the curve.

There is no torque capacity safety device. The overload safety device or interlocking mechanism described above is a load-capable device and has no direct relationship with the "torque capacity" described herein

## 15.3 Do function

The term 'doing capacity' refers to the 'work energy,' which is the amount of work that can be done with each pressurization. The energy available in the flywheel and the main motor is limited for a single operation. If the press machine is used beyond its capacity, the rotational speed will decrease, eventually causing the main motor to stop due to overheating.

## 15.4 Card model

Kamao usually occurs when the torque capacity is exceeded, and it may also occur when a load is applied before the clutch is fully engaged. This phenomenon can have adverse effects on the clutch, so if it is detected, the machine should be stopped immediately before or during operation, and necessary measures should be taken to prevent recurrence.

## 15.5 Allowable eccentricity capability

Basically, eccentric load should be avoided. The occurrence of eccentric load will cause the slider to tilt with the working table. Please limit the use of load to ensure the safety of the machine.

## 15.6 Number of intermittent trips

In order to use the machine in the best condition and ensure the service life of the clutch brake, please use below the intermittent travel (SPM) listed in the regulations. If the intermittent travel exceeds the number above the regulations, the friction pad of the clutch brake will be abnormally worn and faults are likely to occur.

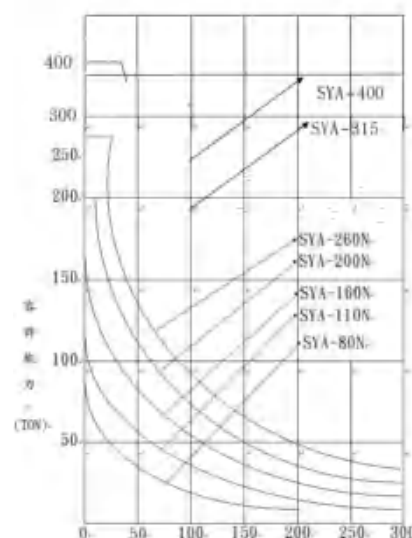

## 16. Appendix

### 16.1 Electrical diagram

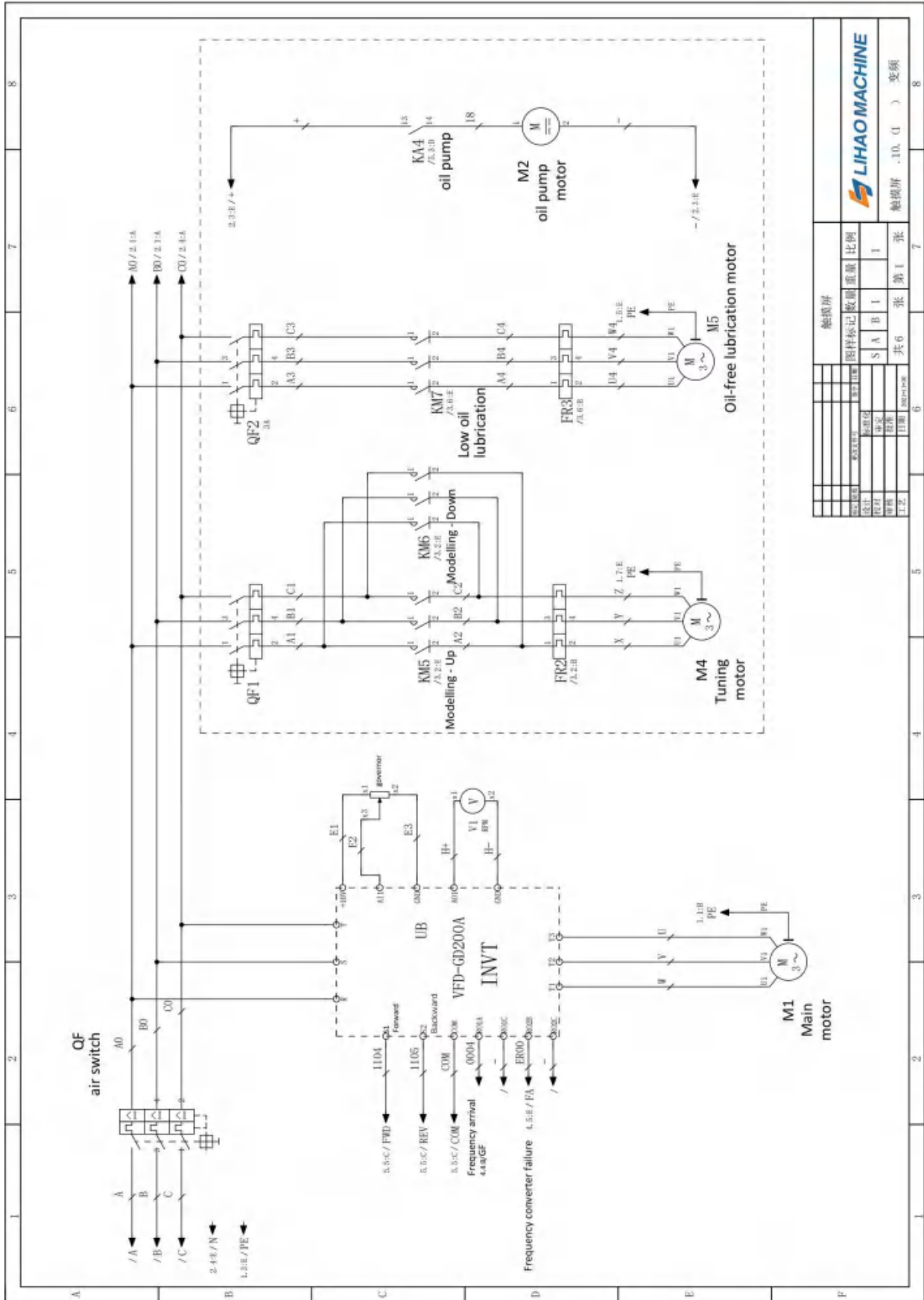

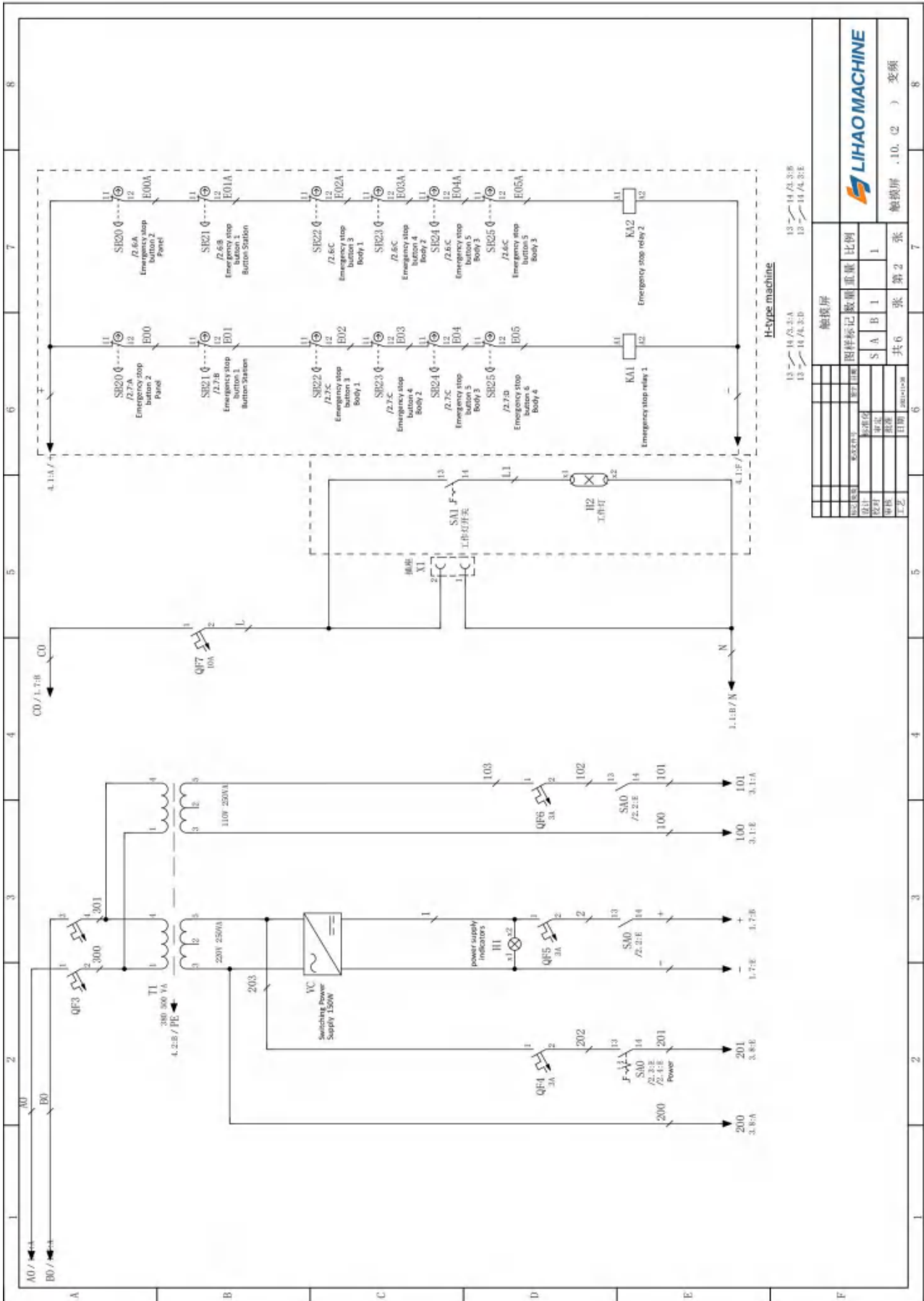

**LIHAO MACHINE**

图例说明: 13-14, 15-16, 17-18, 19-20, 21-22, 23-24, 25-26, 27-28, 29-30, 31-32, 33-34, 35-36, 37-38, 39-40, 41-42, 43-44, 45-46, 47-48, 49-50, 51-52, 53-54, 55-56, 57-58, 59-60, 61-62, 63-64, 65-66, 67-68, 69-70, 71-72, 73-74, 75-76, 77-78, 79-80, 81-82, 83-84, 85-86, 87-88, 89-90, 91-92, 93-94, 95-96, 97-98, 99-100

图例说明: 13-14, 15-16, 17-18, 19-20, 21-22, 23-24, 25-26, 27-28, 29-30, 31-32, 33-34, 35-36, 37-38, 39-40, 41-42, 43-44, 45-46, 47-48, 49-50, 51-52, 53-54, 55-56, 57-58, 59-60, 61-62, 63-64, 65-66, 67-68, 69-70, 71-72, 73-74, 75-76, 77-78, 79-80, 81-82, 83-84, 85-86, 87-88, 89-90, 91-92, 93-94, 95-96, 97-98, 99-100

图例说明: 13-14, 15-16, 17-18, 19-20, 21-22, 23-24, 25-26, 27-28, 29-30, 31-32, 33-34, 35-36, 37-38, 39-40, 41-42, 43-44, 45-46, 47-48, 49-50, 51-52, 53-54, 55-56, 57-58, 59-60, 61-62, 63-64, 65-66, 67-68, 69-70, 71-72, 73-74, 75-76, 77-78, 79-80, 81-82, 83-84, 85-86, 87-88, 89-90, 91-92, 93-94, 95-96, 97-98, 99-100

图例说明: 13-14, 15-16, 17-18, 19-20, 21-22, 23-24, 25-26, 27-28, 29-30, 31-32, 33-34, 35-36, 37-38, 39-40, 41-42, 43-44, 45-46, 47-48, 49-50, 51-52, 53-54, 55-56, 57-58, 59-60, 61-62, 63-64, 65-66, 67-68, 69-70, 71-72, 73-74, 75-76, 77-78, 79-80, 81-82, 83-84, 85-86, 87-88, 89-90, 91-92, 93-94, 95-96, 97-98, 99-100

图例说明: 13-14, 15-16, 17-18, 19-20, 21-22, 23-24, 25-26, 27-28, 29-30, 31-32, 33-34, 35-36, 37-38, 39-40, 41-42, 43-44, 45-46, 47-48, 49-50, 51-52, 53-54, 55-56, 57-58, 59-60, 61-62, 63-64, 65-66, 67-68, 69-70, 71-72, 73-74, 75-76, 77-78, 79-80, 81-82, 83-84, 85-86, 87-88, 89-90, 91-92, 93-94, 95-96, 97-98, 99-100

图例说明: 13-14, 15-16, 17-18, 19-20, 21-22, 23-24, 25-26, 27-28, 29-30, 31-32, 33-34, 35-36, 37-38, 39-40, 41-42, 43-44, 45-46, 47-48, 49-50, 51-52, 53-54, 55-56, 57-58, 59-60, 61-62, 63-64, 65-66, 67-68, 69-70, 71-72, 73-74, 75-76, 77-78, 79-80, 81-82, 83-84, 85-86, 87-88, 89-90, 91-92, 93-94, 95-96, 97-98, 99-100

图例说明: 13-14, 15-16, 17-18, 19-20, 21-22, 23-24, 25-26, 27-28, 29-30, 31-32, 33-34, 35-36, 37-38, 39-40, 41-42, 43-44, 45-46, 47-48, 49-50, 51-52, 53-54, 55-56, 57-58, 59-60, 61-62, 63-64, 65-66, 67-68, 69-70, 71-72, 73-74, 75-76, 77-78, 79-80, 81-82, 83-84, 85-86, 87-88, 89-90, 91-92, 93-94, 95-96, 97-98, 99-100

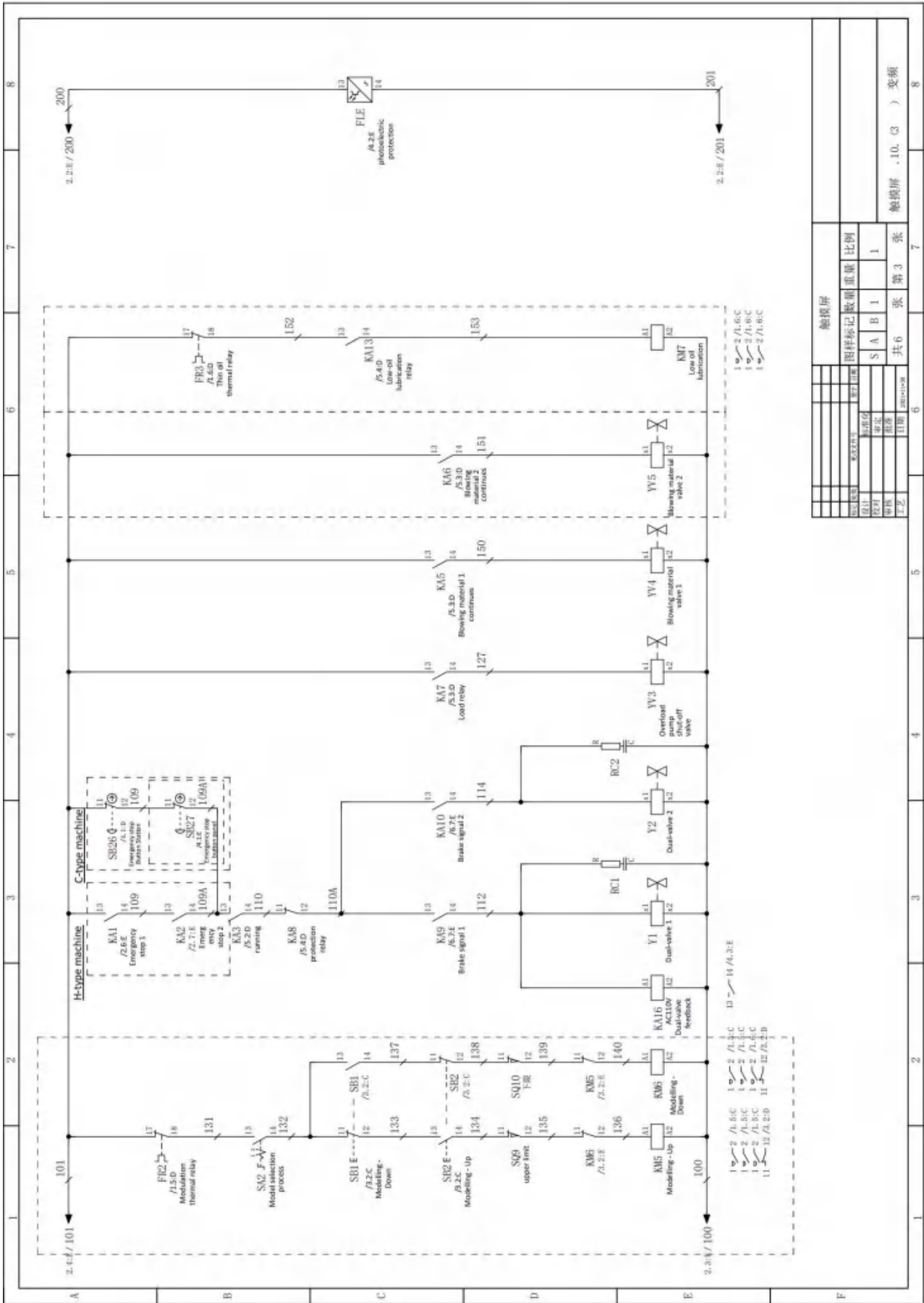

图例	数量	重量	比例
S	A	B	1
共 6 张 第 3 张 船视图 .10.(3) 变频			

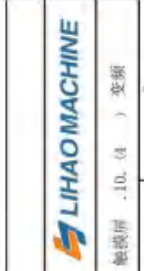
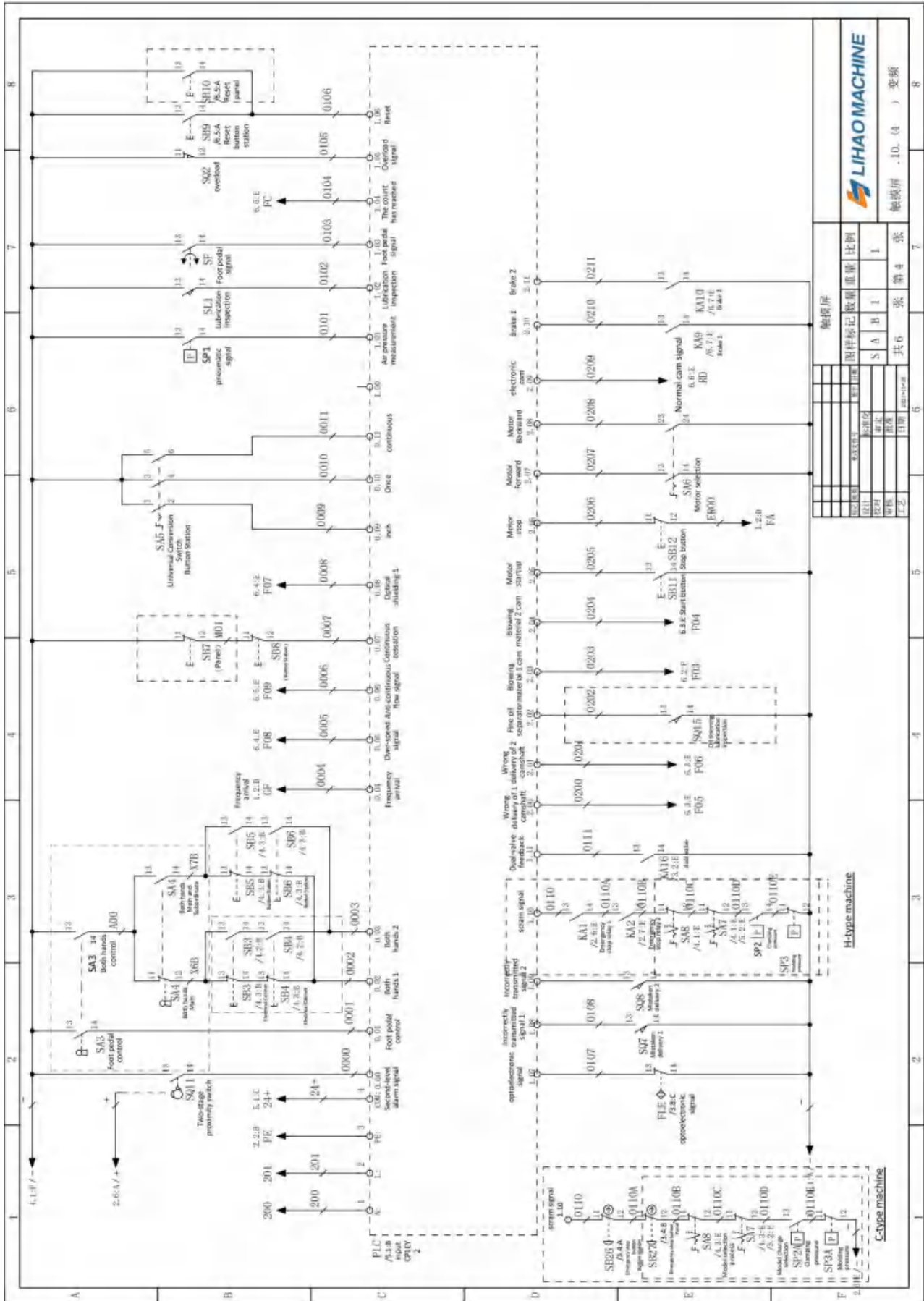

图样标记	比例	张数	张
图样名称	比例	张数	张
图样编号	比例	张数	张
图样日期	比例	张数	张

共 6 张 第 4 张



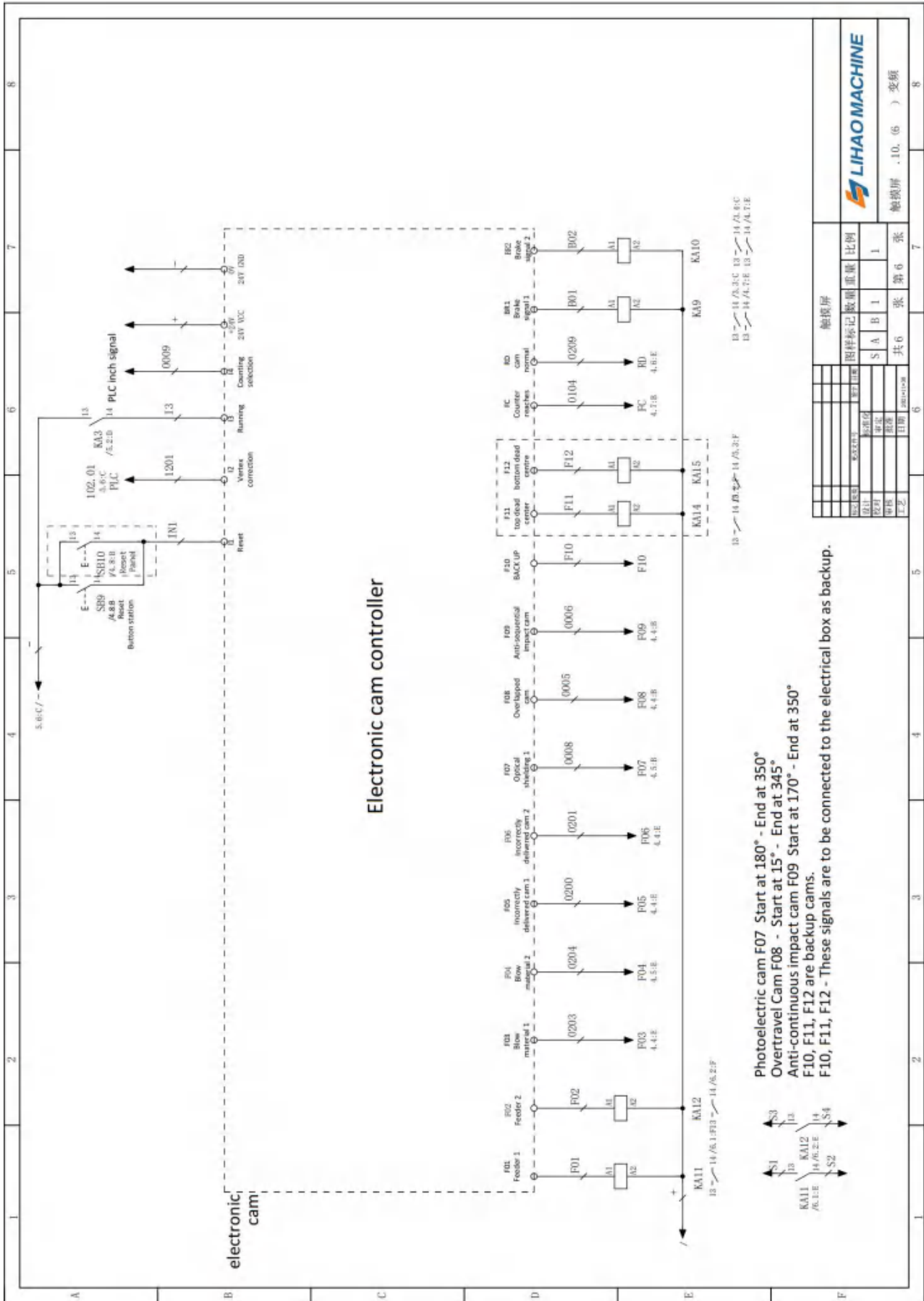

## 16.2 Touch screen

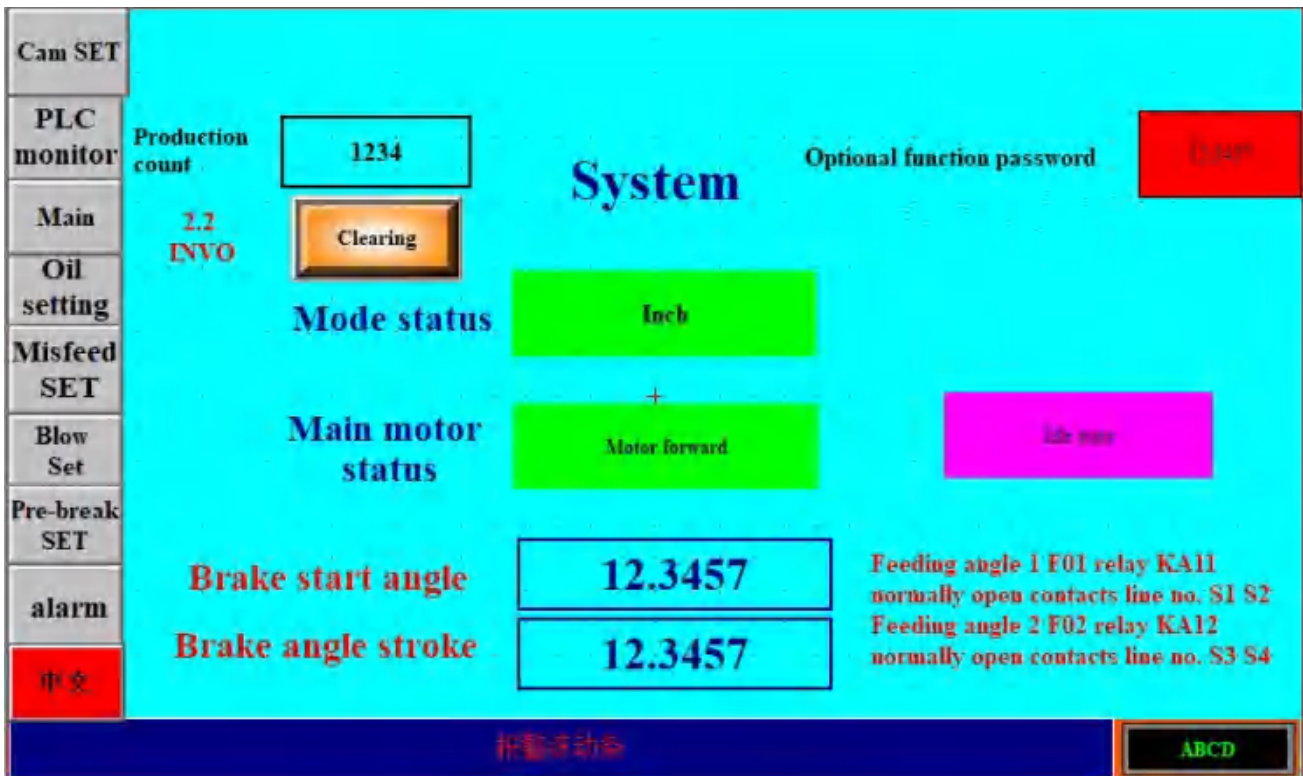

(1) The press machine is equipped with a function for selecting settings, The password is 100200.This allows you to turn on or off the thick and thin oil pumps, and enter the "oil set" screen.However, the switches within this screen cannot be opened or closed at will.

(2) When setting cam, please stop the machine.

(3) The braking angle of the press machine and the required braking travel angle.



(1) start angle setting: This is the angle setting for the starting position.All cam angle settings are made here.

(2) After setting the angle, please make sure to click “Set Over” to return to the main screen.

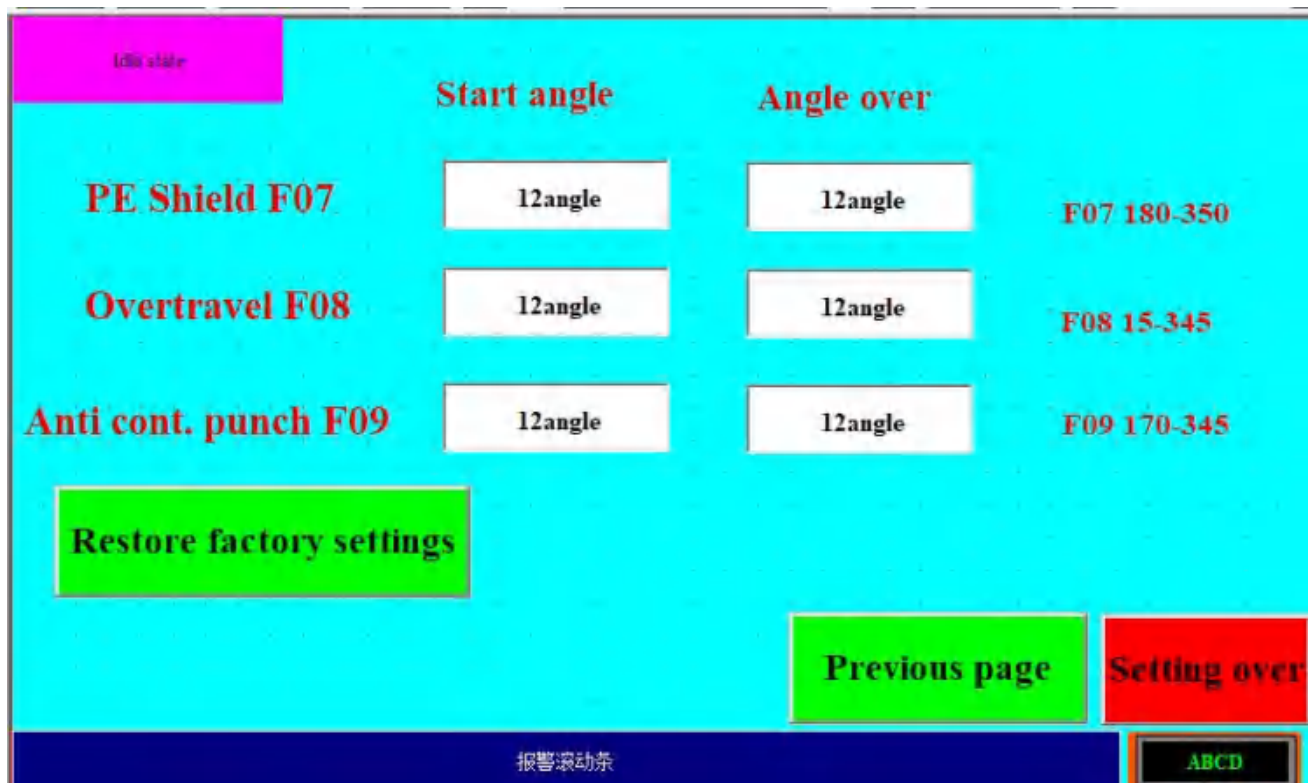
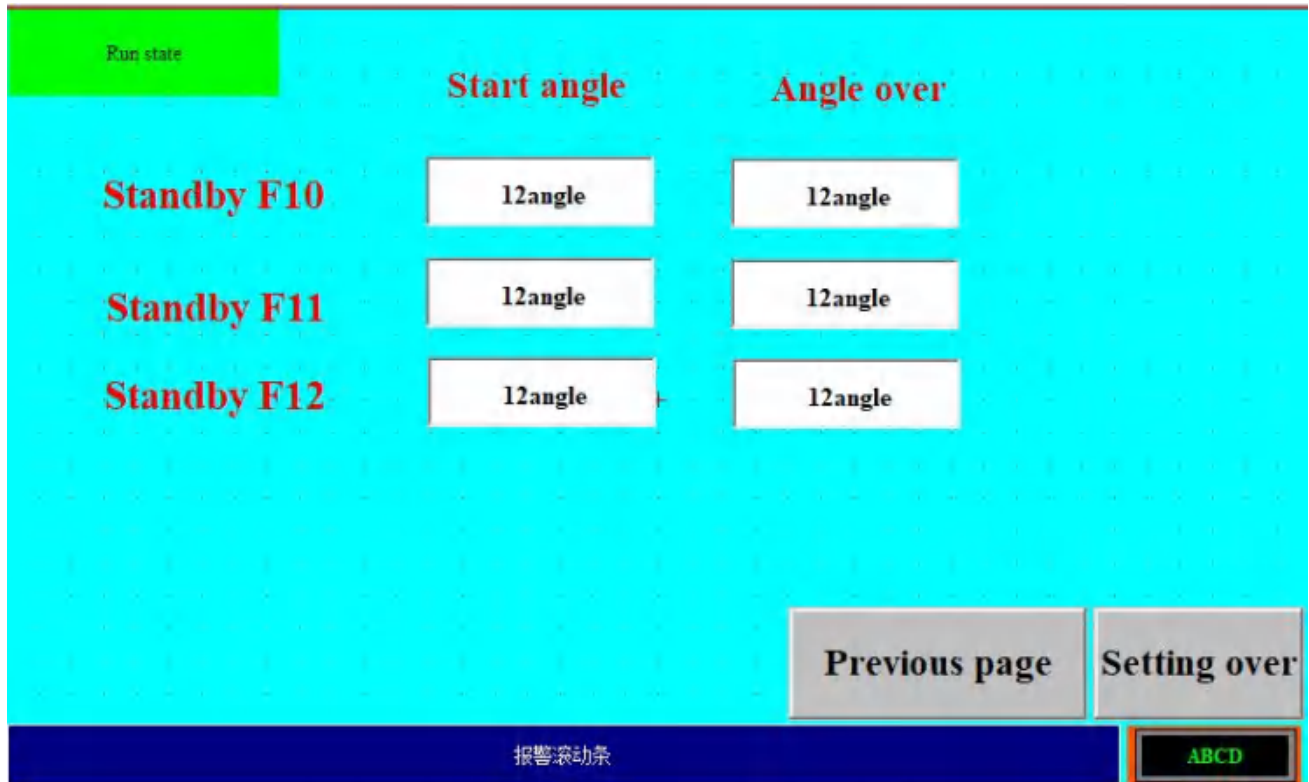



Cam SET			
PLC monitor	Pre-break SET	Mold 1 maintenance	Mold 2 maintenance
Main	Target	Target	Target
Oil setting	12	12	12
Misfeed SET	Current count	Current count	Current count
Blow Set	12	12	12
Pre-break SET			
alarm	Pre-break count OFF	Hand rest	Mold 1 OFF
中文	Current rest	Current rest	Current rest
报警总动条			ABCD



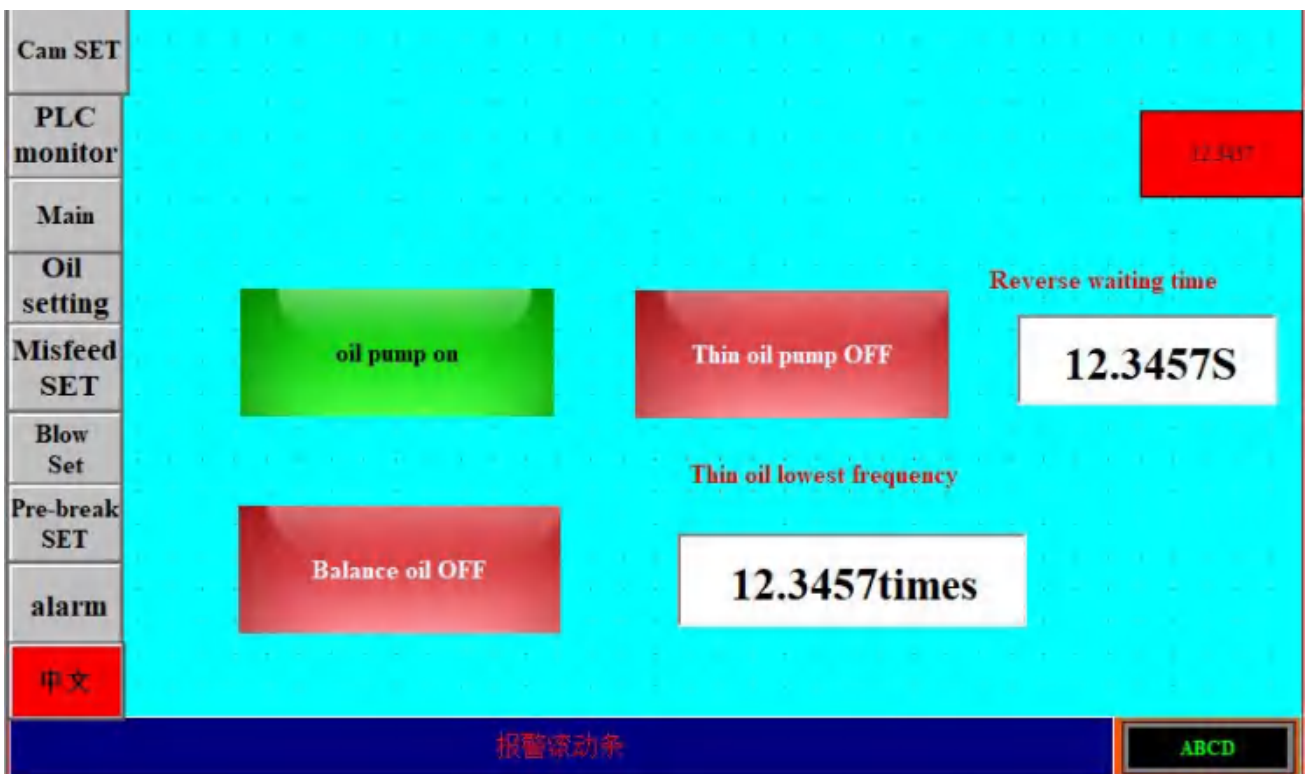

(1) After the stamping machine performs xxx stamping cycles the oiling oil distributor proximity switch operates several times before stopping.



Cam SET	<h2>Blow Set</h2>							
PLC monitor								
Main					Blow 1 F03	<input type="text" value="1234"/> <input type="text" value="1234"/>	Blow 2 F04	<input type="text" value="1234"/> <input type="text" value="1234"/>
Oil setting					Count current val	<input type="text" value="12.3457"/>	Count current val	<input type="text" value="12.3457"/>
Misfeed SET					Interval	<input type="text" value="12.3457"/>	Interval	<input type="text" value="12.3457"/>
Blow Set					Interval: blow 1 time after times of punch; if one blow after one punch, input 1			
Pre-break SET					<input type="button" value="Blow 1 OFF"/>	<input type="button" value="Blow 1 Rest"/>	<input type="button" value="Blow 2 OFF"/>	<input type="button" value="Blow 2 Rest"/>
alarm					<input type="button" value="KA5"/>		<input type="button" value="KA6"/>	
中文					报警清除			<input type="button" value="ABCD"/>

Cam SET	<h2>Misfeed</h2>								
PLC monitor					COM (line:-)	BLUE-COM BLACK-SIGNAL			
Main					Misfeed 1 F05 line no.:0108	<input type="button" value="OFF"/>	<input type="button" value="Angle effective"/>	<input type="button" value="Normally close"/>	<input type="button" value="Blanking OFF"/>
Oil setting					Misfeed 1 angle	+			
Misfeed SET					<input type="text" value="1234"/> <input type="text" value="1234"/>				
Blow Set					Misfeed 2 F06 line no.:0109	<input type="button" value="OFF"/>	<input type="button" value="Angle effective"/>	<input type="button" value="Normally close"/>	<input type="button" value="Blanking OFF"/>
Pre-break SET					Misfeed 2 angle				
alarm					<input type="text" value="1234"/> <input type="text" value="1234"/>				
中文					报警清除			<input type="button" value="ABCD"/>	

Cam SET									
PLC monitor									
Main		X00 Anti 2nd. drop	000		X14 OIL low	100		X30 Cam misfeed 1	200
Oil setting		X01 Pedal selection			X15 Air pressure test			X31 Cam misfeed 2	
Misfeed SET		X02 Double hand 1			X16 Lub test			X32 Thin oil test	
Blow Set		X03 Double hand 2	003		X17 Pedal signal	103		X33 Cam blow 1	103
Pre-break SET		X04 Frequency reach			X20 Count reach			X34 CAM blow 2	
alarm		X05 Overtravel	005		X21 Overload	105		X35 Motor start	105
		X06 Anti cont. punch			X22 Reset			X36 Motor stop	
		X07 Cont. stop	007		X23 PE signal 1	107		X37 Motor forward	207
		X08 PE shielding			X24 Misfeed signal 1			X40 Motor reverse	
		X09 Inch mode			X25 Misfeed signal 2			X41 CAM normal	109
		X10 Single mode	010		X26 Emergency stop	110		X42 Brake 1	
		X11 Cont. mode			X27 Bivalue feedback			X43 Brake 2	
									OUT
	 								

Cam SET									
PLC monitor									
Main		Y00 Running 1	100.00		Y10 Anti 2nd drop	101.00		Y20 Running 1	102.00
Oil setting		Y01 Balancing cylinder oil			Y11 Thin oil lub			Y21 Brake signal	
Misfeed SET		Y02 Motor start light			Y12			Y22	
Blow Set		Y03 Thick oil pump			Y13			Y23	
Pre-break SET		Y04 Blow 1			Y14 Motor forward			Y24	
alarm		Y05 Blow 2			Y15 Motor reverse			Y25	
		Y06 Overload			Y16 star start			Y26	
		Y07 Abnormal alarm	100.07		Y17 Triangle start	101.07		Y27	102.07
									IN
	 								

Cam SET						
PLC monitor	Number	Date	Time	Alarm value	Alarm description	End time
	0	2026/03/13	15:48:39	40.000	报警信息3	2026/03/14 16:53:26
Main	1	2026/03/13	15:48:39	30.000	报警信息2	
Oil setting	2	2026/03/13	15:48:39	20.000	报警信息1	2026/03/13 16:51:59
	3	2026/03/13	15:48:39	10.000	报警信息0	
Misfeed SET						
Blow Set						
Pre-break SET						
alarm						
中文						

报警滚动条

ABCD

# Product execution standard JIS

**passed inspection**

**Identification of product:** \_\_\_\_\_

**Product specification, model:** \_\_\_\_\_

**Product General Inspector:** \_\_\_\_\_

**Quality Management Department Manager:** \_\_\_\_\_

**Date of manufacture:** \_\_\_\_\_

# Warranty card

<b>User name</b>		<b>Factory number</b>	
<b>Production type</b>		<b>Date of production</b>	
<b>Date of purchase</b>		<b>Invoice number</b>	

## Instructions for warranty

Thank you for using Lihao stamping equipment ,in order to ensure the interests of users,our company sincerely promises to provide you with the following services with this warranty card.

1. Lihao power press is guaranteed for one year from the date of purchase.
2. The machine can be repaired free of charge within the stipulated warranty period for any faults that occur in manufacturing problems.
3. The following conditions do not belong to the scope of free maintenance,but can be implemented by fee-based maintenance,life-long service.
  - 1) Don't show the warranty card or the warranty card without the company's seal confirmation.
  - 2) Faults caused by accidental factors or user failure to operate according to random instructions.
  - 3) Fill in the warranty card that the products does not conform to or be altered with the repaired product.
  - 4) Over the stipulated warranty period,the repairs will continue.

Seal:

Service email: [export@lihaomachine.com](mailto:export@lihaomachine.com)

Please keep this card properly.



中国 . 深圳 . 力豪机械设备有限公司  
CHINA SHENZHEN LIHAO MACHINE EQUIPMENT CO. LTD.

---

Address: No. 454, Jinbi Road, Shanjie Industrial Zone, Bi Ling  
Village, Ping Shan Town, Longgang District, Shenzhen City  
Website: [www.lihaomachine.com](http://www.lihaomachine.com)